



# JIS B 6339-BT

Code system Kodifizierung	<b>I100</b>
Technical information Technische Auskünfte	<b>I101</b>
Applications index Anwendungen	<b>I102-103</b>
Arbors and adaptors JIS B 6339-BT Aufnahmen JIS B 6339-BT	<b>I104-145</b>
Antivibratory adaptors JIS B 6339-BT Schwingungsgedämpfte Aufnahmen JIS B 6339-BT	<b>I106-107,130</b>
Sets Sätze	<b>I133</b>
Special tool request Sonderwerkzeug-Anfrage	<b>I146</b>



## Code system / Kodifizierung

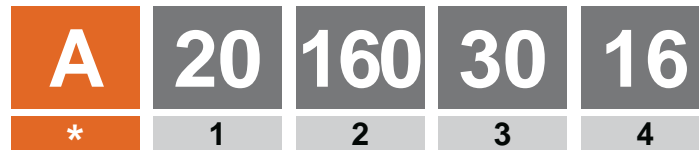

\* Antivibratory adaptors  
Schwingungsgedämpfte Aufnahmen

### 1 Model Modell

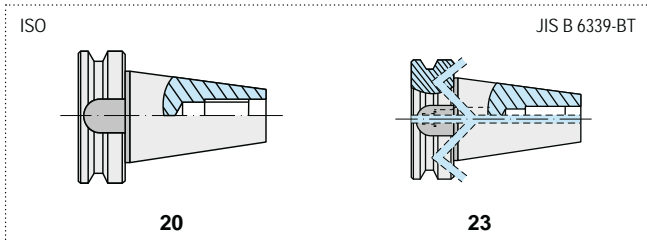

### 3 Arbor size Aufnahmengröße

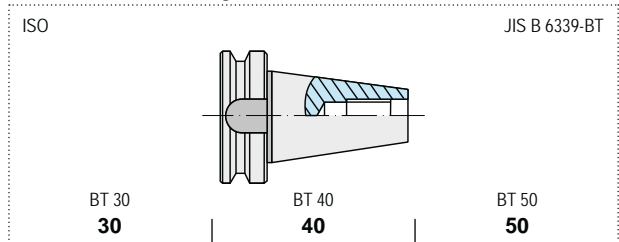

### 2 Arbor type Aufnahmen-Typ

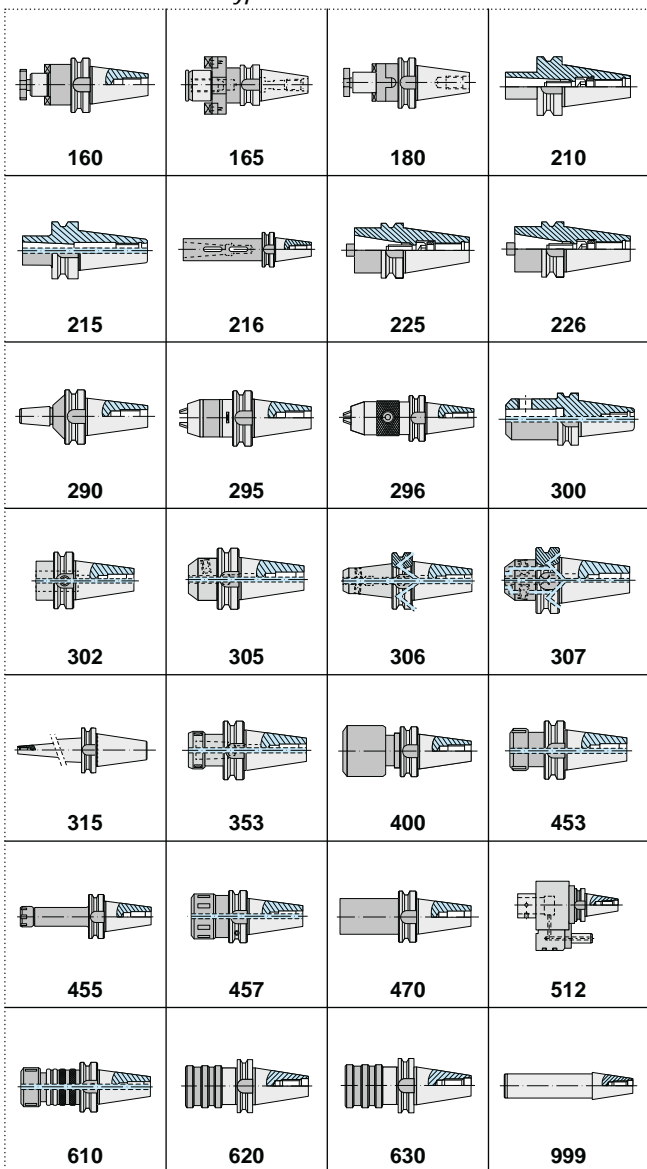

### 4 Adaptor size Adaptergröße

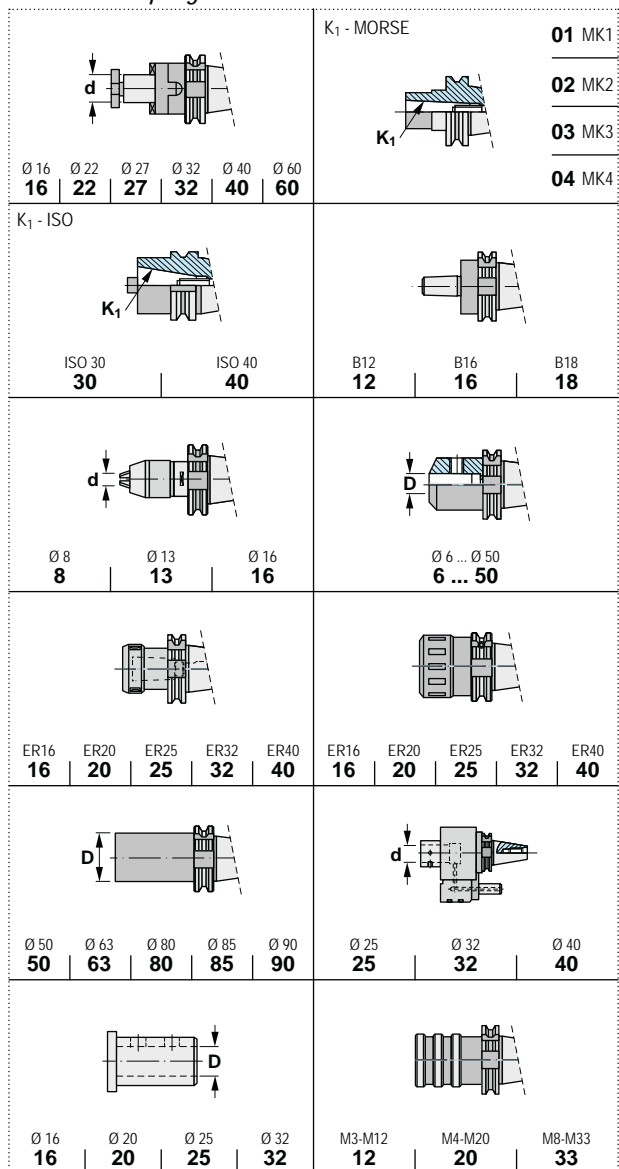

## AT3 TECHNICAL CHARACTERISTICS OF THE TOOLHOLDERS AT3 TECHNISCHE EIGENSCHAFTEN DER AUFNAHMEN

### MATERIAL:

- Chromium-manganese carburised steel 1.7131 (16MnCr5).

### EXECUTION:

- Carburised, hardened and tempered.
- Surface hardness HRC 58±2 (670±40 HV30)
- Depth of carburised layer minimum 0.5 mm.
- Tensile strength in core minimum 800 N/mm<sup>2</sup> after carburizing.

### ACCURACY:

- Taper according to DIN 254
- Taper angle:  
tolerance AT 3 DIN 7178 part 1 and DIN 2080 part 1.
- Other tolerances according to DIN 7160 and 7168.
- Taper surface roughness RZ<0,001 mm.

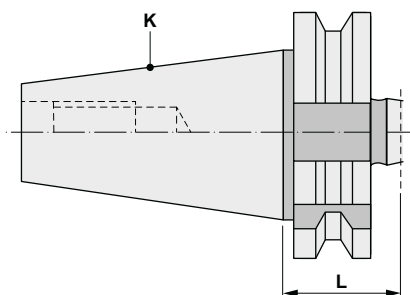

### PREBALANCED TOOLHOLDERS VORGEWUCHTETE AUFNAHMEN

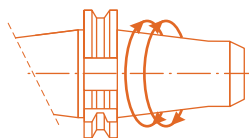

ISO 40 ▶ 8000 rpm      ISO 50 ▶ 8000 rpm

### MATERIALIEN:

- Legierter aufgekohlter Stahl mit Chrom-Mangan 1.7131 (16MnCr5).

### KONSTRUKTIONS DATEN:

- Aufgekohlt, gehärtet und angelassen.
- Oberflächenhärte HRC 58±2 (670±40 HV30)
- Aufgekohlt auf minimum 0,5 mm Tiefe.
- Zugfestigkeit im Kern minimum 800 N/mm<sup>2</sup> nach der Aufkohlung.

### GENAUIGKEIT:

- Dorn nach DIN 254
- Kegelwinkel:  
Toleranz AT 3 DIN 7178 Teil 1 und DIN 2080 Teil 1.
- Andere Toleranzen entsprechend DIN 7160 und 7168.
- Rauigkeit der Oberfläche RZ<0,001 mm.

K	AT3 mm
ISO 30	0,002
ISO 40	0,003
ISO 45	0,003
ISO 50	0,004
ISO 60	0,005

### TOLERANCE AT:

- Indicates the tolerance of measuring plane D between the real and the theoretical value of the taper conicity.
- This value of measuring plane D must always be less (negative), never more (positive) in order to GUARANTEE a good toolholder fixation at the bigger taper diameter.

### TOLERANZ AT:

- Zeigt die Toleranz auf der Messebene D zwischen dem tatsächlichen Wert der Kegelkonizität und dem theoretischen Wert.
- Dieser Wert auf der Messebene D sollte immer minus (negativ) sein, nie plus (positiv), um für einen guten Halt des Futter in den größeren Durchmesser des Kegels zu GARANTIEREN.

## 20 JIS B 6339 - BT

FORM A: SIMILAR DIN 69871 AD

ÄHNLICH WIE DIN 69871 AD

Without through hole / Ohne Durchgangsbohrung

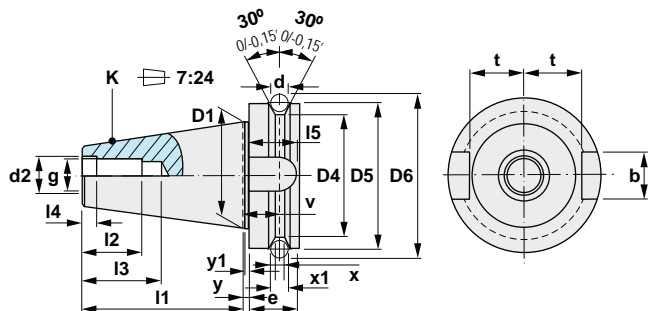

K	D1	l1±0,2	d2 H8	g 6H	l2 min	l3 min	l4+0,5/0	b H12	l5 min	t 0/-0,2
30	31,75	48,4	12,5	M 12	24	34	7	16,1	17	16,3
35	38,10	56,4	12,5	M 12	24	34	7	16,1	20	19,6
40	44,45	65,4	17,0	M 16	30	43	9	16,1	21	22,6
45	57,15	82,8	21,0	M 20	38	53	11	19,3	26	29,1
50	69,85	101,8	25,0	M 24	45	62	13	25,7	31	35,1

K	D4	D5 h8	e	V±0,1	X	X1±0,1/0	y±0,4	y1±0,5/0	d9	e1±0,1	e2 max
30	38	46	20	13,6	4	8	2	7	4	21	5
35	43	53	22	14,6	5	10	2	7	-	-	-
40	53	63	25	16,6	5	10	2	9	4	27	5
45	73	85	30	21,2	6	12	3	11	5	35	6
50	85	100	35	23,2	7	15	3	13	6	42	7

## 23 JIS B 6339 - BT

FORM B: SIMILAR DIN 69871 AD+B

ÄHNLICH WIE DIN 69871 AD+B

With central coolant feed and through the collar  
Mit zentraler Kühlmittelzufuhr und durch den Bund

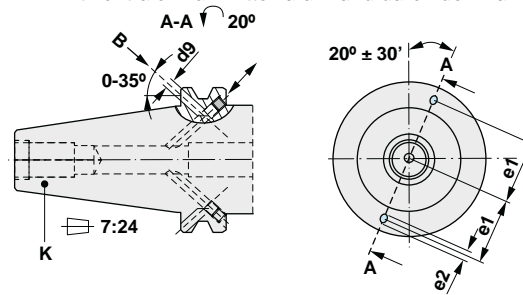

**Arbors and adaptors JIS B 6339-BT**  
**Aufnahmen JIS B 6339-BT**

**20.160**



Page / Seite I104

**23.160**



Page / Seite I105

**20.165**



Page / Seite I108

**20.180**



Page / Seite I109

**20.210**



Page / Seite I110

**23.210**



Page / Seite I111

**20.215**



Page / Seite I112

**23.215**



Page / Seite I113

**20.216**



Page / Seite I114

**20.225**



Page / Seite I115

**20.226**



Page / Seite I116

**20.290**



Page / Seite I117

**20.295**



Page / Seite I118

**20.296**



Page / Seite I119

**23.296**



Page / Seite I120

**20.300**



Page / Seite I121

**23.300**



Page / Seite I122

**20.302**



Page / Seite I123

**23.302**



Page / Seite I124

**20.305**



Page / Seite I125

**23.306**



Page / Seite I126-127

**23.307**



Page / Seite I128

**23.315**



Page / Seite I129

**20.353**



Page / Seite I131

**20.400**



Page / Seite I132

**20.453**



Page / Seite I134

**23.453**



Page / Seite I135

**20.455**



Page / Seite I136

**20.457**



Page / Seite I137

**23.457**



Page / Seite I138

**Arbors and adaptors JIS B 6339-BT**  
**Aufnahmen JIS B 6339-BT**

20.470



Page / Seite I139

20.512



Page / Seite I140

20.610



Page / Seite I141

23.610



Page / Seite I142

20.620



Page / Seite I143

20.630



Page / Seite I144

20.999



Page / Seite I145

**Antivibratory adaptors JIS B 6339-BT**  
**Schwingungsgedämpfte Aufnahmen JIS B 6339-BT**

A20.160 Cylindrical  
Zylindrische Form



Page / Seite I106

A20.160 Conical  
Konische Form



Page / Seite I107

A20.315



Page / Seite I130

**Sets JIS B 6339-BT**  
**Sätze JIS B 6339-BT**

SET-C20/32



Page / Seite I133







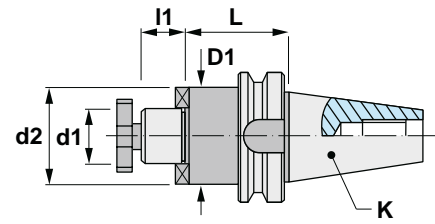

Characteristics:  
Shell mill adaptors.  
JIS B 6339-BT  
For cutters with driving slot DIN 138.

Eigenschaften:  
Aufsteckfräsdorne.  
JIS B 6339-BT  
Für Fräser mit Quernut DIN 138.



## 20.160

Reference Bezeichnung	K ISO	d1 h6	L	l1	d2	D1				
20.160.30.16	30	16	40	17	38	-	10008	86016	11103	0,620
20.160.30.22	30	22	40	19	48	-	10010	86022	11004	0,700
20.160.30.27	30	27	45	21	58	-	10012	86027	11005	0,870
20.160.40.16	40	16	40	17	38	-	10008	86016	11103	1,190
20.160.40.16/100	40	16	100	17	38	38	10008	86016	11103	1,580
20.160.40.22	40	22	45	19	48	-	10010	86022	11004	1,290
20.160.40.22/100	40	22	100	19	48	48	10010	86022	11004	2,180
20.160.40.27	40	27	50	21	58	-	10012	86027	11005	1,650
20.160.40.27/100	40	27	100	21	58	58	10012	86027	11005	2,420
20.160.40.32	40	32	50	24	63	-	10016	86032	11105	1,730
20.160.40.32/125	40	32	125	24	78	63	10016	86032	11105	3,100
20.160.40.40	40	40	55	27	73	-	10020	86040	11006	2,130
20.160.50.16	50	16	55	17	38	-	10008	86016	11103	4,100
20.160.50.16/150	50	16	150	17	38	38	10008	86016	11103	4,880
20.160.50.22	50	22	55	19	48	-	10010	86022	11004	4,150
20.160.50.22/150	50	22	150	19	48	48	10010	86022	11004	5,500
20.160.50.27	50	27	60	21	58	-	10012	86027	11005	4,280
20.160.50.27/150	50	27	150	21	58	58	10012	86027	11005	6,300
20.160.50.32	50	32	60	24	78	-	10016	86032	11105	4,320
20.160.50.32/150	50	32	150	24	78	63	10016	86032	11105	8,300
20.160.50.40	50	40	65	27	88	-	10020	86040	11006	5,370
20.160.50.40/150	50	40	150	27	88	73	10020	86040	11006	9,530
20.160.50.50	50	50	65	30	90	-	10024	86050	11008	5,700



**Characteristics:**  
Shell mill adaptors.  
JIS B 6339-BT  
For cutters with driving slot  
DIN 138.



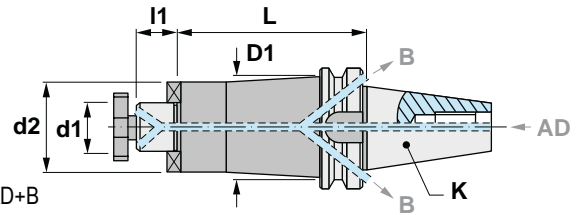

Similar to DIN 69871 - Form AD+B

**Eigenschaften:**  
Aufsteckfräsdorne.  
JIS B 6339-BT.  
Für Fräser mit Quernut  
DIN 138.

Ähnlich wie DIN 69871 - Form AD+B



## 23.160

Reference Bezeichnung	K ISO	d1 h6	L	l1	d2	D1				
23.160.40.16	40	16	40	17	38	-	10008	86016	11103	1,150
23.160.40.16/100	40	16	100	17	38	38	10008	86016	11103	1,450
23.160.40.22	40	22	45	19	48	-	10010	86022	11004	1,310
23.160.40.22/100	40	22	100	19	48	48	10010	86022	11004	2,080
23.160.40.27	40	27	50	21	58	-	10012	86027	11005	1,570
23.160.40.27/100	40	27	100	21	58	58	10012	86027	11005	2,590
23.160.40.32	40	32	50	24	63	-	10016	86032	11105	1,700
23.160.40.32/125	40	32	125	24	78	63	10016	86032	11105	3,140
23.160.40.40	40	40	55	27	73	-	10020	86040	11006	2,070
23.160.50.16	50	16	55	17	38	-	10008	86016	11108	3,780
23.160.50.16/150	50	16	150	17	38	38	10008	86016	11108	4,590
23.160.50.22	50	22	55	19	48	-	10010	86022	11004	3,970
23.160.50.22/150	50	22	150	19	48	48	10010	86022	11004	5,230
23.160.50.27	50	27	60	21	58	-	10012	86027	11005	4,230
23.160.50.27/150	50	27	150	21	58	58	10012	86027	11005	6,010
23.160.50.32	50	32	60	24	78	-	10016	86032	11105	4,340
23.160.50.32/150	50	32	150	24	78	63	10016	86032	11105	6,400
23.160.50.40	50	40	65	27	88	-	10020	86040	11006	5,250
23.160.50.40/150	50	40	150	27	88	73	10020	86040	11006	9,130
23.160.50.50	50	50	65	30	90	-	10024	86050	11008	5,560



**Characteristics:**  
Cylindrical antivibratory shell mill adaptors. JIS B 6339-BT  
For cutters with driving slot DIN 138.

**Eigenschaften:**  
Zylindrische schwingungsgedämpfte Aufsteckfräsdorne.  
JIS B 6339-BT  
Für Fräser mit Quernut DIN 138.

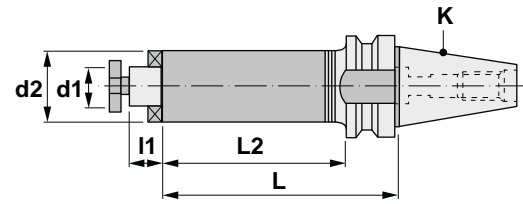

## A20.160

Reference Bezeichnung	K ISO	d1 h6	L	L2	l1	d2				
A20.160.40.16/150-38	40	16	150	123	17	38	10008	86016	11103	2,110
A20.160.40.16/200-38	40	16	200	173	17	38	10008	86016	11103	2,560
A20.160.40.16/250-38	40	16	250	223	17	38	10008	86016	11103	3,000
A20.160.40.16/300-38	40	16	300	273	17	38	10008	86016	11103	3,450
A20.160.40.22/150-48	40	22	150	123	19	48	10010	86022	11004	2,790
A20.160.40.22/200-48	40	22	200	173	19	48	10010	86022	11004	3,500
A20.160.40.22/250-48	40	22	250	223	19	48	10010	86022	11004	4,210
A20.160.40.22/300-48	40	22	300	273	19	48	10010	86022	11004	4,920
A20.160.40.27/150-58	40	27	150	123	21	58	10012	86027	11005	3,620
A20.160.40.27/200-58	40	27	200	173	21	58	10012	86027	11005	4,660
A20.160.40.27/250-58	40	27	250	223	21	58	10012	86027	11005	5,690
A20.160.40.27/300-58	40	27	300	273	21	58	10012	86027	11005	6,730
A20.160.50.16/150-38	50	16	150	112	17	38	10008	86016	11103	4,720
A20.160.50.16/200-38	50	16	200	162	17	38	10008	86016	11103	5,160
A20.160.50.16/250-38	50	16	250	212	17	38	10008	86016	11103	5,610
A20.160.50.16/300-38	50	16	300	262	17	38	10008	86016	11103	6,060
A20.160.50.16/400-38	50	16	400	362	17	38	10008	86016	11103	6,950
A20.160.50.22/200-48	50	22	200	162	19	48	10010	86022	11004	6,050
A20.160.50.22/250-48	50	22	250	212	19	48	10010	86022	11004	6,760
A20.160.50.22/300-48	50	22	300	262	19	48	10010	86022	11004	7,470
A20.160.50.22/400-48	50	22	400	362	19	48	10010	86022	11004	8,890
A20.160.50.22/500-48	50	22	500	462	19	48	10010	86022	11004	10,310
A20.160.50.22/200-58	50	22	200	162	19	58	10010	86022	11004	7,110
A20.160.50.22/250-58	50	22	250	212	19	58	10010	86022	11004	8,150
A20.160.50.22/300-58	50	22	300	262	19	58	10010	86022	11004	9,180
A20.160.50.22/400-58	50	22	400	362	19	58	10010	86022	11004	11,260
A20.160.50.22/500-58	50	22	500	462	19	58	10010	86022	11004	13,330
A20.160.50.27/200-58	50	27	200	162	21	58	10012	86027	11005	7,140
A20.160.50.27/250-58	50	27	250	212	21	58	10012	86027	11005	8,180
A20.160.50.27/300-58	50	27	300	262	21	58	10012	86027	11005	9,210
A20.160.50.27/400-58	50	27	400	362	21	58	10012	86027	11005	11,290
A20.160.50.27/500-58	50	27	500	462	21	58	10012	86027	11005	13,360
A20.160.50.32/200-78	50	32	200	162	24	78	10016	86032	11105	9,890
A20.160.50.32/250-78	50	32	250	212	24	78	10016	86032	11105	11,760
A20.160.50.32/300-78	50	32	300	262	24	78	10016	86032	11105	13,640
A20.160.50.32/400-78	50	32	400	362	24	78	10016	86032	11105	17,390
A20.160.50.32/500-78	50	32	500	462	24	78	10016	86032	11105	21,140



**Characteristics:**  
 Conical antivibratory shell mill adaptors. JIS B 6339-BT  
 For cutters with driving slot DIN 138.

**Eigenschaften:**  
 Konische schwingungsgedämpfte Aufsteckfräsdorne.  
 JIS B 6339-BT  
 Für Fräser mit Quernut DIN 138.

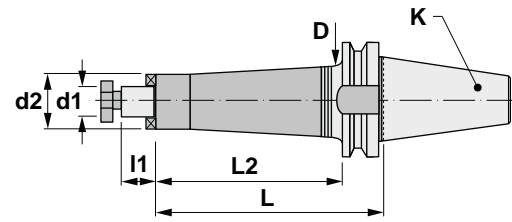

## A20.160

Reference Bezeichnung	K ISO	d1 h6	L	L2	D	I1	d2				
A20.160.40.16/150	40	16	150	123	50	17	38	10008	86016	11103	2,550
A20.160.40.16/200	40	16	200	173	50	17	38	10008	86016	11103	3,150
A20.160.40.16/250	40	16	250	223	50	17	38	10008	86016	11103	3,750
A20.160.40.16/300	40	16	300	273	50	17	38	10008	86016	11103	4,350
A20.160.40.22/150	40	22	150	123	50	19	48	10010	86022	11004	2,750
A20.160.40.22/200	40	22	200	173	50	19	48	10010	86022	11004	3,430
A20.160.40.22/250	40	22	250	223	50	19	48	10010	86022	11004	4,110
A20.160.40.22/300	40	22	300	273	50	19	48	10010	86022	11004	4,790
A20.160.50.16/150	50	16	150	112	80	17	38	10008	86016	11103	6,510
A20.160.50.16/200	50	16	200	162	80	17	38	10008	86016	11103	7,630
A20.160.50.16/250	50	16	250	212	80	17	38	10008	86016	11103	8,750
A20.160.50.16/300	50	16	300	262	80	17	38	10008	86016	11103	9,860
A20.160.50.16/400	50	16	400	362	80	17	38	10008	86016	11103	12,100
A20.160.50.22/200	50	22	200	162	80	19	48	10010	86022	11004	8,100
A20.160.50.22/250	50	22	250	212	80	19	48	10010	86022	11004	9,400
A20.160.50.22/300	50	22	300	262	80	19	48	10010	86022	11004	10,680
A20.160.50.22/400	50	22	400	362	80	19	48	10010	86022	11004	13,260
A20.160.50.22/500	50	22	500	462	80	19	48	10010	86022	11004	15,840
A20.160.50.27/200	50	27	200	162	80	21	58	10012	86027	11005	8,790
A20.160.50.27/250	50	27	250	212	80	21	58	10012	86027	11005	10,310
A20.160.50.27/300	50	27	300	262	80	21	58	10012	86027	11005	11,830
A20.160.50.27/400	50	27	400	362	80	21	58	10012	86027	11005	14,870
A20.160.50.27/500	50	27	500	462	80	21	58	10012	86027	11005	17,920

### SPECIAL FOR MOULD AND DIE MAKERS

Vibration reduced up to 60% compared to any other conventional shell mill adaptor, as they are manufactured with materials and mechanisms having antivibration properties.

### BESONDERS EMPFOHLEN FÜR WERKZEUG- UND FORMENBAU

60% weniger Schwingungen im Vergleich mit anderen konventionellen Aufsteckfräsdornen, da diese Ausführung mit schwingungsdämpfenden Materialien und Mechanismen hergestellt wird.

### COMPARISON WHEN USING AN ANTIVIBRATORY TOOLHOLDER

### VERGLEICH ZWISCHEN EINER KONVENZIONELLEN UND EINER SCHWINGUNGSGEDÄMPFTEN AUFNAHME

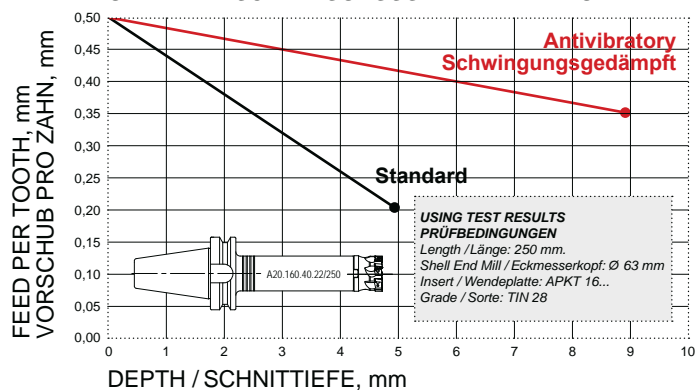



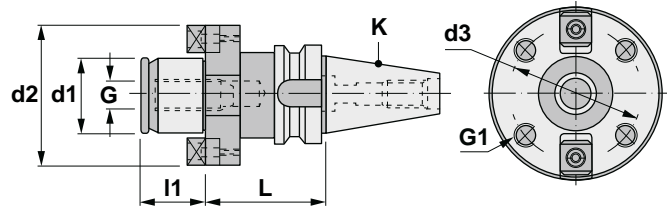

**Characteristics:**  
Adaptors for indexable milling cutters.  
JIS B 6339-BT / DIN 6357 - Form A

**Eigenschaften:**  
Zwischenhülsen für Fräser.  
JIS B 6339-BT / DIN 6357 - Form A



## 20.165

Reference Bezeichnung	K ISO	d1 g5	L	d2	d3	G	G1	I1	KG
20.165.40.40	40	40	60	89	66,7	M-20	M-12	30	2,700
20.165.50.40	50	40	70	89	66,7	M-20	M-12	30	5,510
20.165.50.60	50	60	80	129	101,6	M-30	M-16	40	8,100

Reference Bezeichnung	2x 	2x 
20.165.40.40	80040	11006
20.165.50.40	80040	11006
20.165.50.60	80060	11012



**Characteristics:**  
Combi-Shell mill adaptor.  
JIS B 6339-BT  
For cutters with keyway or driving slot  
DIN 138.

**Eigenschaften:**  
Kombi-Aufsteckfräsdorne.  
JIS B 6339-BT  
Für Fräser mit Längsnut oder  
Stimmitnehmer DIN 138.

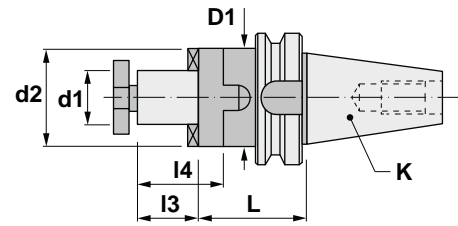

## 20.180

Reference Bezeichnung	K ISO	d1 h6	L	I3	I4	d2	D1				
20.180.30.16	30	16	50	17	27	32	-	10008	60116	88016	0,620
20.180.30.22	30	22	50	19	31	40	-	10010	60122	88022	0,790
20.180.30.27	30	27	55	21	33	48	-	10012	60127	88027	0,730
20.180.40.16	40	16	55	17	27	32	-	10008	60116	88016	1,260
20.180.40.16/100	40	16	100	17	27	32	35	10008	60116	88016	1,510
20.180.40.22	40	22	55	19	31	40	-	10010	60122	88022	1,390
20.180.40.22/100	40	22	100	19	31	40	48	10010	60122	88022	1,970
20.180.40.27	40	27	55	21	33	48	-	10012	60127	88027	1,560
20.180.40.27/100	40	27	100	21	33	48	48	10012	60127	88027	2,170
20.180.40.32	40	32	60	24	38	58	-	10016	60132	88032	1,560
20.180.40.32/100	40	32	100	24	38	58	58	10016	60132	88032	2,780
20.180.40.40	40	40	60	27	41	70	-	10020	60140	88040	1,800
20.180.50.16	50	16	70	17	27	32	-	10008	60116	88016	4,100
20.180.50.16/125	50	16	125	17	27	32	35	10008	60116	88016	4,480
20.180.50.22	50	22	70	19	31	40	-	10010	60122	88022	4,230
20.180.50.22/125	50	22	125	19	31	40	48	10010	60122	88022	4,950
20.180.50.27	50	27	70	21	33	48	-	10012	60127	88027	4,170
20.180.50.27/125	50	27	125	21	33	48	60	10012	60127	88027	5,420
20.180.50.32	50	32	70	24	38	58	-	10016	60132	88032	4,360
20.180.50.32/125	50	32	125	24	38	58	78	10016	60132	88032	6,270
20.180.50.40	50	40	70	27	41	70	-	10020	60140	88040	4,520
20.180.50.40/125	50	40	125	27	41	70	78	10020	60140	88040	6,950
20.180.50.50	50	50	70	30	46	90	-	10024	60150	88050	5,000





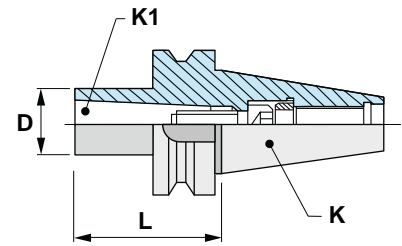

**Characteristics:**  
Reducing adaptors.  
JIS B 6339-BT  
For tools with Morse taper shank  
and drawbar thread  
DIN 228-A.

**Eigenschaften:**  
Reduzierhülsen.  
JIS B 6339-BT  
Für Werkzeuge mit Morsekegel  
und Anzugsgewinde DIN 228-A.



## 20.210

Reference Bezeichnung	K ISO	K1 MORSE	L	D	
20.210.30.01	30	1	50	25	0,510
20.210.30.02	30	2	65	32	0,590
20.210.30.03	30	3	80	40	0,760
20.210.40.01	40	1	50	25	1,080
20.210.40.02	40	2	50	32	1,130
20.210.40.03	40	3	70	40	1,270
20.210.40.04	40	4	95	48	1,520
20.210.50.01	50	1	45	25	3,850
20.210.50.02	50	2	60	32	3,860
20.210.50.03	50	3	65	40	3,870
20.210.50.04	50	4	70	48	3,870
20.210.50.05	50	5	100	63	4,020

Reference Bezeichnung			
20.210.30.01	16105	19312	11106
20.210.30.02	16105	19315	12110
20.210.30.03	16105	19318	12012
20.210.40.01	16205	19516	11206
20.210.40.02	16205	19416	18010
20.210.40.03	16205	19420	11312
20.210.40.04	16205	19322	12016
20.210.50.01	16205	19624	11206
20.210.50.02	16205	19324	11110
20.210.50.03	16205	19524	11212
20.210.50.04	16205	19424	12016
20.210.50.05	16205	19338	11020



**Characteristics:**  
 Reducing adaptors.  
 JIS B 6339-BT  
 For tools with Morse taper shank  
 and drawbar thread  
 DIN 228-A.  
 Similar to DIN 69871 - Form AD+B

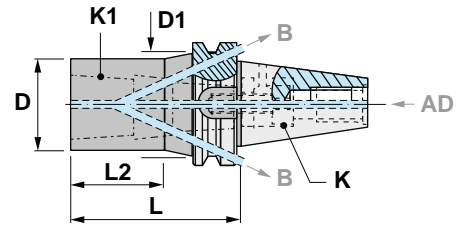

**Eigenschaften:**  
 Reduzierhülsen.  
 JIS B 6339-BT  
 Für Werkzeuge mit Morsekegel  
 und Anzugsgewinde DIN 228-A.  
 Ähnlich wie DIN 69871 - Form AD+B

## 23.210

Reference Bezeichnung	K ISO	K1 MORSE	L	D	D1	L2	
23.210.40.01	40	1	50	25	45	16	1,050
23.210.40.02	40	2	50	32	50	19	1,090
23.210.40.03	40	3	70	40	50	42	1,270
23.210.40.04	40	4	95	48	-	-	1,480
23.210.50.01	50	1	45	25	80	16	3,680
23.210.50.02	50	2	60	32	80	23	3,920
23.210.50.03	50	3	65	40	80	28	3,910
23.210.50.04	50	4	70	48	80	37	3,790
23.210.50.05	50	5	100	63	80	66	4,080

Reference Bezeichnung			
23.210.40.01	16205	19516	18006
23.210.40.02	16205	19416	18010
23.210.40.03	16205	19420	18012
23.210.40.04	16205	19322	18016
23.210.50.01	16205	19624	18006
23.210.50.02	16205	19324	18110
23.210.50.03	16205	19524	18112
23.210.50.04	16205	19424	18016
23.210.50.05	16205	19338	18020





**Characteristics:**  
Reducing adaptors.  
JIS B 6339-BT  
For tools with Morse taper shank  
and tang DIN 228-B shank.

**Eigenschaften:**  
Reduzierhülsen.  
JIS B 6339-BT  
Für Werkzeuge mit Morsekegel  
und Austreiblappen DIN 228-B.

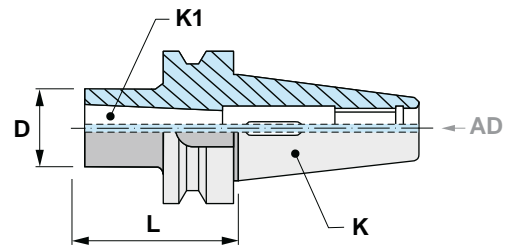

## 20.215

Reference Bezeichnung	K ISO	K1 MORSE	L	D	
20.215.30.01	30	1	50	25	0,470
20.215.30.02	30	2	62	32	0,530
20.215.30.03	30	3	78	40	0,600
20.215.40.01	40	1	50	25	1,060
20.215.40.02	40	2	50	32	1,070
20.215.40.03	40	3	70	40	1,180
20.215.40.04	40	4	95	48	1,390
20.215.50.01	50	1	45	25	3,750
20.215.50.02	50	2	60	32	3,770
20.215.50.03	50	3	65	40	3,800
20.215.50.04	50	4	95	48	4,000
20.215.50.05	50	5	105	63	4,100



**Characteristics:**  
Reducing adaptors.  
JIS B 6339-BT  
For tools with Morse taper shank  
and tang DIN 228-B.  
Similar to DIN 69871 - Form AD+B

**Eigenschaften:**  
Reduzierhülsen.  
JIS B 6339-BT  
Für Werkzeuge mit Morsekegel  
und Austreibblappen DIN 228-B.  
Ähnlich wie DIN 69871 - Form AD+B

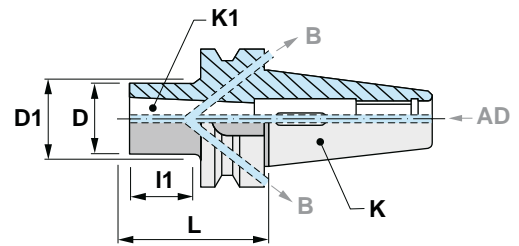

## 23.215

Reference Bezeichnung	K ISO	K1 MORSE	L	D	D1	I1	KG
23.215.40.01	40	1	50	25	45	16	1,080
23.215.40.02	40	2	50	32	50	18	1,080
23.215.40.03	40	3	70	40	50	42	1,170
23.215.40.04	40	4	95	48	-	-	1,380
23.215.50.01	50	1	45	25	80	16	3,730
23.215.50.02	50	2	60	32	80	23	3,650
23.215.50.03	50	3	65	40	80	28	3,930
23.215.50.04	50	4	95	48	80	49	3,930
23.215.50.05	50	5	105	63	80	71	3,830



**Characteristics:**

Long reducing adaptors. JIS B 6339-BT  
For tools with Morse taper shank and tang  
DIN 228-B.

**Eigenschaften:**

Lange Reduzierhülsen. JIS B 6339-BT  
Für Werkzeuge mit Morsekegel  
und Austreibblappen DIN 228-B.

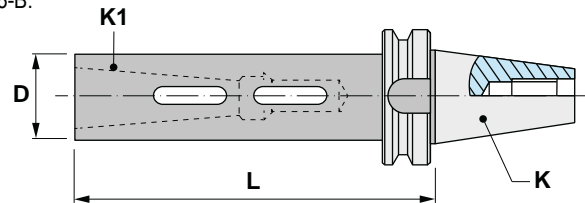

## 20.216

Reference Bezeichnung	K ISO	K1 MORSE	L	D	
20.216.30.01	30	1	115	25	0,760
20.216.30.02	30	2	125	32	0,930
20.216.30.03	30	3	145	40	1,320
20.216.40.01	40	1	115	25	1,250
20.216.40.02	40	2	125	32	1,540
20.216.40.03	40	3	145	40	1,890
20.216.50.01	50	1	120	25	4,100
20.216.50.02	50	2	135	32	4,290
20.216.50.03	50	3	155	40	4,650
20.216.50.04	50	4	180	48	5,130
20.216.50.05	50	5	215	63	6,330







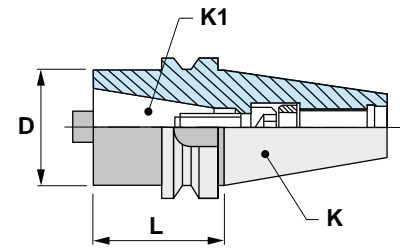

**Characteristics:**  
Reducing adaptors.  
JIS B 6339-BT  
For tools with DIN 2080 taper shank.

**Eigenschaften:**  
Reduzierhülsen.  
JIS B 6339-BT  
Für Werkzeuge mit DIN 2080 Kegel.



## 20.225

Reference Bezeichnung	K ISO	K1 DIN 2080	L	D	
20.225.40.30	40	30	50	50	1,200
20.225.40.40	40	40	100	63	2,230
20.225.50.30	50	30	50	50	3,810
20.225.50.40	50	40	70	63	3,980
20.225.50.50	50	50	120	97	6,440

Reference Bezeichnung			
20.225.40.30	16205	19320	11312
20.225.40.40	16205	19322	12016
20.225.50.30	16205	19524	11112
20.225.50.40	16205	19424	12016
20.225.50.50	16205	19438	12024





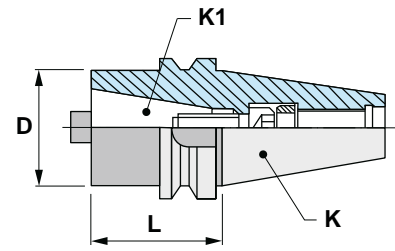

Characteristics:  
Reducing adaptors.  
JIS B 6339-BT  
For tools with DIN 69871-A and  
BT shanks.

Eigenschaften:  
Reduzierhülsen.  
JIS B 6339-BT  
Für Werkzeuge mit DIN 69871-A  
und BT Kegel.



## 20.226

Reference Bezeichnung	K ISO	K1 DIN 69871 JIS B 6339-BT	L	D	
20.226.40.30	40	30	50	50	1,210
20.226.40.40	40	40	100	63	2,250
20.226.50.30	50	30	50	50	3,840
20.226.50.40	50	40	70	63	4,090
20.226.50.50	50	50	120	97	6,580

Reference Bezeichnung			
20.226.40.30	16205	19320	11412
20.226.40.40	16205	19322	12116
20.226.50.30	16205	19524	11412
20.226.50.40	16205	19424	12116
20.226.50.50	16205	19438	12124



**Characteristics:**  
Drill chuck adaptors.  
JIS B 6339-BT  
For drill chucks with DIN 238 taper.

**Eigenschaften:**  
Bohrfutteraufnahmen.  
JIS B 6339-BT  
Für Bohrfutter mit DIN 238 Kegel.

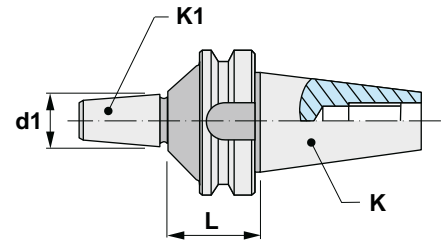

## 20.290

Reference Bezeichnung	K ISO	K1 DIN	L	d1	
20.290.30.12	30	B-12	27	12,065	0,460
20.290.30.16	30	B-16	27	15,733	0,490
20.290.40.12	40	B-12	32	12,065	1,070
20.290.40.16	40	B-16	32	15,733	1,090
20.290.40.18	40	B-18	32	17,780	1,100
20.290.50.16	50	B-16	43	15,733	3,880
20.290.50.18	50	B-18	43	17,780	3,790

### MU

 I199

Ref. / Bez.      Accessories / Zubehör

MU      Standard keyless drill chucks DIN 238  
Standard Schnellspann-Bohrfutter DIN 238



### MP

 I200

Ref. / Bez.      Accessories / Zubehör

MP      Super precision keyless drill chucks DIN 238  
Höchst-Genauigkeit-Selbstspannbohrfutter DIN 238



### MK

 I201

Ref. / Bez.      Accessories / Zubehör

MK      Super precision keyless drill chucks DIN 238 with gripping tongue  
Höchst-Genauigkeit-Selbstspannbohrfutter DIN 238 mit Schlüsselflächen





**Characteristics:**

Self clamping short precision drill chucks.  
JIS B 6339-BT  
For right turn only.

**\* SUPPLIED WITH WRENCH**

**Eigenschaften:**

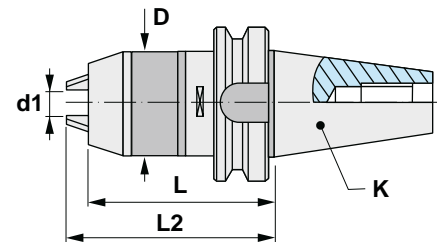

Selbstspann-Kurzbohrfutter,  
Genauigkeitsausführung.  
JIS B 6339-BT  
Nur für rechtslaufende Bearbeitungen.

**\* LIEFERUNG MIT SCHLÜSSEL**



## 20.295

Reference Bezeichnung	K ISO	d1	D	L	L2 max	
20.295.30.08	30	0,3-8	38	73	79	1,100
20.295.40.08	40	0,3-8	38	78	84	1,500
20.295.40.13	40	1-13	48	86	97	1,900
20.295.40.16	40	3-16	55	105	116	2,300
20.295.50.13	50	1-13	48	97	108	4,600
20.295.50.16	50	3-16	55	95	106	4,700

Reference Bezeichnung		
20.295.30.08	50008	11206
20.295.40.08	50008	11206
20.295.40.13	50013	11108
20.295.40.16	50016	11108
20.295.50.13	50013	11108
20.295.50.16	50016	11108



Characteristics:  
CNC-Universal precision drill chucks.  
JIS B 6339-BT  
For left and right hand turn.

**\* SUPPLIED WITH WRENCH**

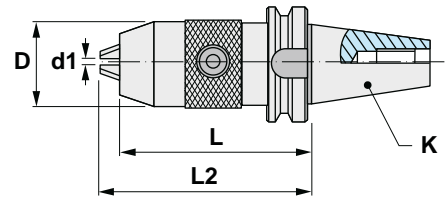

Eigenschaften:  
CNC-Universal Bohrfutter,  
Genauigkeitsausführung.  
JIS B 6339-BT  
Für links- und rechtslaufende Bearbeitungen.

**\* LIEFERUNG MIT SCHLÜSSEL**



## 20.296

Reference Bezeichnung	K ISO	d1	D	L	L2 max	
20.296.40.13	40	1-13	54	96	105	2,040
20.296.40.16	40	3-16	57	99	106	2,220
20.296.50.13	50	1-13	54	107	116	4,380
20.296.50.16	50	3-16	57	110	117	4,480

Reference Bezeichnung		3x 
20.296.40.13	5006	60313
20.296.40.16	5006	60313
20.296.50.13	5006	60313
20.296.50.16	5006	60313





Characteristics:  
CNC-Universal precision drill chucks.  
JIS B 6339-BT  
For left and right hand turn.

**\* SUPPLIED WITH WRENCH**

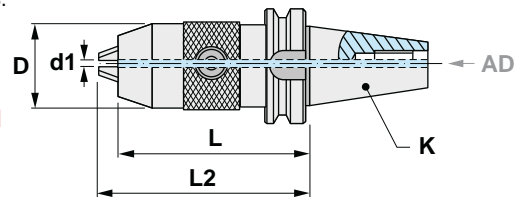

Eigenschaften:  
CNC-Universal Bohrfutter,  
Genauigkeitsausführung.  
JIS B 6339-BT  
Für links- und rechtslaufende  
Bearbeitungen.

**\* LIEFERUNG MIT SCHLÜSSEL**



## 23.296

Reference Bezeichnung	K ISO	d1	D	L	L2 max	
23.296.40.13	40	1-13	54	96	105	2,040
23.296.40.16	40	3-16	57	99	106	2,220
23.296.50.13	50	1-13	54	107	116	4,380
23.296.50.16	50	3-16	57	110	117	4,480

Reference Bezeichnung		3x 
23.296.40.13	5006	60313
23.296.40.16	5006	60313
23.296.50.13	5006	60313
23.296.50.16	5006	60313

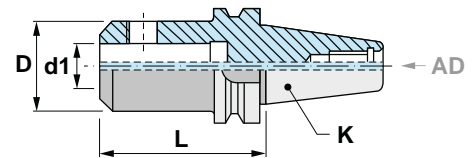

**Characteristics:**

Weldon end mill adaptors.  
JIS B 6339-BT  
For cutters with cylindrical shank  
and Weldon flat DIN 1835-B.

**Eigenschaften:**

Zylinderschaft-Aufnahme Weldon.  
JIS B 6339-BT  
Für Fräser mit zylindrischem  
Schaft und Weldon-Fläche  
DIN 1835-B.

## 20.300

Reference Bezeichnung	K ISO	d1 H4	L	D		
20.300.30.06	30	6	50	25	15106	0,500
20.300.30.08	30	8	50	28	15108	0,520
20.300.30.10	30	10	50	35	15110	0,610
20.300.30.12	30	12	50	42	15212	0,620
20.300.30.14	30	14	50	44	15212	0,625
20.300.30.16	30	16	63	48	15314	0,850
20.300.30.18	30	18	63	50	15314	0,880
20.300.40.06	40	6	50	25	15106	0,940
20.300.40.08	40	8	50	28	15108	0,970
20.300.40.10	40	10	50	35	15110	1,030
20.300.40.12	40	12	50	42	15212	1,120
20.300.40.14	40	14	50	44	15212	1,130
20.300.40.16	40	16	63	48	15314	1,340
20.300.40.18	40	18	63	50	15314	1,370
20.300.40.20	40	20	63	52	15216	1,380
20.300.40.25	40	25	100	65	2 x 15218	2,370
20.300.40.32	40	32	100	72	2 x 15220	2,710
20.300.40.40	40	40	120	90	2 x 15220	4,280
20.300.50.06	50	6	63	25	15106	2,860
20.300.50.08	50	8	63	28	15108	2,890
20.300.50.10	50	10	63	35	15110	2,920
20.300.50.12	50	12	63	42	15212	3,070
20.300.50.14	50	14	63	44	15212	3,110
20.300.50.16	50	16	63	48	15314	3,170
20.300.50.18	50	18	63	50	15314	3,190
20.300.50.20	50	20	63	52	15216	3,260
20.300.50.25	50	25	80	65	2 x 15218	3,910
20.300.50.32	50	32	100	72	2 x 15220	4,670
20.300.50.40	50	40	120	90	2 x 15220	6,310
20.300.50.50	50	50	120	98	2 x 15024	6,700

## 42.300

 I182

Ref. / Bez.

Accessories / Zubehör

42.300

Short and long reducing bushings DIN 1835-B Form A and B  
Kurze und lange Reduzierhülsen DIN 1835-B Form A und B





**Characteristics:**  
Weldon end mill adaptors.  
JIS B 6339-BT  
For cutters with cylindrical shank  
and Weldon flat DIN 1835-B.



Similar to DIN 69871 - Form AD+B

**Eigenschaften:**  
Zylinderschaft-Aufnahme Weldon.  
JIS B 6339-BT  
Für Fräser mit zylindrischem  
Schaft und Weldon-Fläche  
DIN 1835-B.

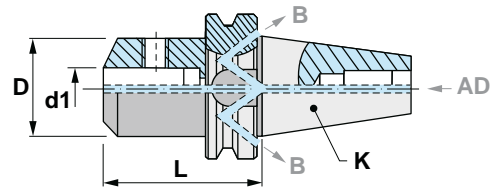
Ähnlich wie DIN 69871 - Form AD+B



## 23.300

Reference Bezeichnung	K ISO	d1 H4	L	D		
23.300.40.06	40	6	50	25	15106	1,070
23.300.40.08	40	8	50	28	15108	1,090
23.300.40.10	40	10	63	35	15110	1,230
23.300.40.12	40	12	63	42	15212	1,300
23.300.40.14	40	14	63	44	15212	1,320
23.300.40.16	40	16	63	48	15314	1,380
23.300.40.18	40	18	63	50	15314	1,390
23.300.40.20	40	20	63	52	15216	1,410
23.300.40.25	40	25	90	65	2 x 15218	2,250
23.300.40.32	40	32	100	72	2 x 15220	2,730
23.300.40.40	40	40	110	90	2 x 15220	3,960
23.300.50.06	50	6	63	25	15106	3,770
23.300.50.08	50	8	63	28	15108	3,790
23.300.50.10	50	10	65	35	15110	3,850
23.300.50.12	50	12	80	42	15212	4,000
23.300.50.14	50	14	80	44	15212	4,020
23.300.50.16	50	16	80	48	15314	4,100
23.300.50.18	50	18	80	50	15314	4,200
23.300.50.20	50	20	80	52	15216	4,250
23.300.50.25	50	25	100	65	2 x 15218	4,870
23.300.50.32	50	32	105	72	2 x 15220	5,180
23.300.50.40	50	40	120	90	2 x 15220	5,900
23.300.50.50	50	50	120	98	2 x 15024	6,930

## 42.300

 1182

Ref. / Bez.	Accessories / Zubehör
42.300	Short and long reducing bushings DIN 1835-B Form A and B Kurze und lange Reduzierhülsen DIN 1835-B Form A und B



**Characteristics:**

Short end mill adaptors.

JIS B 6339-BT

For cutters and tooling with cylindrical shank and Weldon flat DIN 1835-B.

**Eigenschaften:**

Kurze Aufsteckfräsdorne.

JIS B 6339-BT

Für Fräser und Werkzeuge mit zylindrischem Schaft und Weldon-Fläche DIN 1835-B.

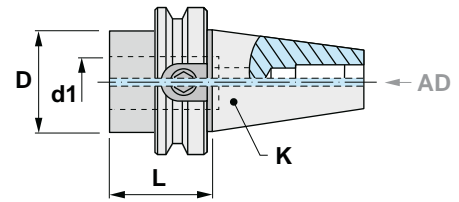

## 20.302

Reference Bezeichnung	K ISO	d1 H4	L	D	
20.302.30.16	30	16	32	32	0,400
20.302.30.20	30	20	34	36	0,370
20.302.40.16	40	16	35	45	1,060
20.302.40.20	40	20	35	45	1,000
20.302.40.25	40	25	35	45	0,920
20.302.40.32	40	32	45	50	0,880
20.302.50.16	50	16	44	70	3,800
20.302.50.20	50	20	44	70	3,730
20.302.50.25	50	25	44	70	3,620
20.302.50.32	50	32	44	70	3,470

Reference Bezeichnung	
20.302.30.16	15114
20.302.30.20	15014
20.302.40.16	15214
20.302.40.20	15116
20.302.40.25	15016
20.302.40.32	15020
20.302.50.16	15314
20.302.50.20	15216
20.302.50.25	15118 + 15218
20.302.50.32	15020 + 15120



**Characteristics:**  
Short end mill adaptors.  
JIS B 6339-BT  
For cutters and tooling with cylindrical shank and Weldon flat DIN 1835-B.  
Similar to DIN 69871 - Form AD+B

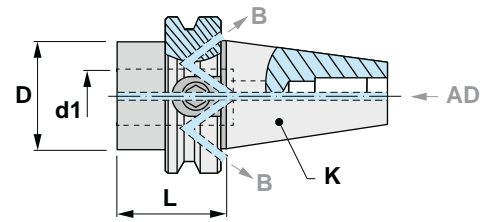

**Eigenschaften:**  
Kurze Aufsteckfräsdorne.  
JIS B 6339-BT  
Für Fräser und Werkzeuge mit zylindrischem Schaft und Weldon-Fläche DIN 1835-B.  
Ähnlich wie DIN 69871 - Form AD+B

## 23.302

Reference Bezeichnung	K ISO	d1 H4	L	D	
23.302.40.16	40	16	35	45	1,070
23.302.40.20	40	20	35	45	0,990
23.302.40.25	40	25	35	45	0,890
23.302.40.32	40	32	45	50	0,880
23.302.50.16	50	16	44	70	3,880
23.302.50.20	50	20	44	70	3,710
23.302.50.25	50	25	44	70	3,620
23.302.50.32	50	32	44	70	3,450

Reference Bezeichnung	
23.302.40.16	15214
23.302.40.20	15116
23.302.40.25	15016
23.302.40.32	15020
23.302.50.16	15314
23.302.50.20	15216
23.302.50.25	15118 + 15218
23.302.50.32	15020 + 15120

### 42.610

 I183

Ref. / Bez.      Accessories / Zubehör

42.610      Tapping head with axial compensation DIN 1835-B  
Gewindeschneidfutter mit Längenausgleich DIN 1835-B



### 42.620

 I184

Ref. / Bez.      Accessories / Zubehör

42.620      Quick change tapping head with axial compensation DIN 1835-B+E  
Gewindeschneid-Schnellwechselfutter mit Längenausgleich DIN 1835-B+E



**Characteristics:**

End mill adaptors type Whistle-Notch.

JIS B 6339-BT

For tools with cylindrical shank and tightening inclined flat DIN 1835-E.

**Eigenschaften:**



Whistle-Notch Zylinderschaft-Aufnahme.

JIS B 6339-BT

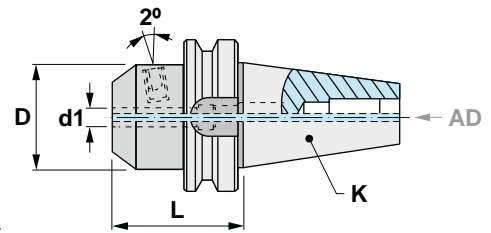
Für Werkzeuge mit zylindrischem Schaft und geneigter Spannfläche DIN 1835-E.



## 20.305

Reference Bezeichnung	K ISO	d1 H4	L	D			
20.305.30.06	30	6	50	25	19005	15106	0,550
20.305.30.08	30	8	50	28	19106	15108	0,540
20.305.30.10	30	10	50	35	19008	15110	0,590
20.305.30.12	30	12	50	42	19110	15212	0,660
20.305.30.14	30	14	50	44	19110	15212	0,630
20.305.30.16	30	16	50	48	19012	15314	0,650
20.305.30.18	30	18	60	50	19012	15314	0,820
20.305.40.06	40	6	50	25	19005	15106	1,100
20.305.40.08	40	8	50	28	19106	15108	1,140
20.305.40.10	40	10	63	35	19008	15110	1,260
20.305.40.12	40	12	50	42	19110	15212	1,320
20.305.40.14	40	14	50	44	19110	15212	1,360
20.305.40.16	40	16	63	48	19012	15314	1,430
20.305.40.18	40	18	63	50	19012	15314	1,440
20.305.40.20	40	20	63	52	19016	15216	1,430
20.305.40.25	40	25	90	65	19020	2 x 15218	2,240
20.305.40.32	40	32	100	72	19020	2 x 15220	2,730
20.305.50.06	50	6	63	25	19005	15106	3,700
20.305.50.08	50	8	63	28	19106	15108	3,730
20.305.50.10	50	10	65	35	19008	15110	3,810
20.305.50.12	50	12	80	42	19110	15212	4,160
20.305.50.14	50	14	80	44	19110	15212	4,070
20.305.50.16	50	16	80	48	19012	15314	4,110
20.305.50.18	50	18	80	50	19012	15314	4,190
20.305.50.20	50	20	80	52	19016	15216	4,170
20.305.50.25	50	25	100	65	19020	2 x 15218	5,010
20.305.50.32	50	32	105	72	19020	2 x 15220	5,270
20.305.50.40	50	40	120	90	19020	2 x 15220	6,650







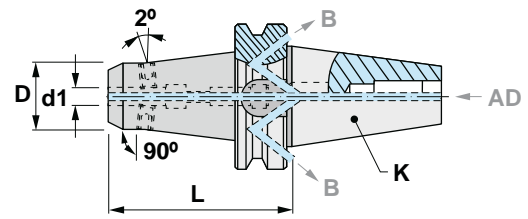

**Characteristics:**  
 Combined end mill adaptors type  
 Weldon / Whistle-Notch.  
 JIS B 6339-BT  
 For tools with cylindrical shank and  
 tightening inclined flat DIN 1835-  
 B+E.  
 Similar to DIN 69871 - Form AD+B



**Eigenschaften:**  
 Kombi-Aufnahme Typ Weldon /  
 Whistle-Notch.  
 JIS B 6339-BT.  
 Für Werkzeuge mit zylindrischem  
 Schaft und geneigter Spannfläche  
 DIN 1835-B+E.  
 Ähnlich wie DIN 69871 - Form AD+B

## 23.306

Reference Bezeichnung	K ISO	d1 H4	L	D	D1	2x 	
23.306.40.06/100	40	6	100	22	28	15006	1,240
23.306.40.06/130	40	6	130	22	28	15006	1,340
23.306.40.06/160	40	6	160	22	33	15006	1,560
23.306.40.08/100	40	8	100	24	30	15008	1,270
23.306.40.08/130	40	8	130	24	30	15008	1,420
23.306.40.08/160	40	8	160	24	35	15008	1,620
23.306.40.10/100	40	10	100	30	38	15010	1,460
23.306.40.10/130	40	10	130	30	38	15010	1,630
23.306.40.10/160	40	10	160	30	39	15010	1,850
23.306.40.12/100	40	12	100	32	40	15012	1,440
23.306.40.12/130	40	12	130	32	40	15012	1,730
23.306.40.12/160	40	12	160	32	43	15012	1,950
23.306.40.14/100	40	14	100	32	40	15012	1,470
23.306.40.14/130	40	14	130	32	40	15012	1,650
23.306.40.14/160	40	14	160	32	44	15012	2,200
23.306.40.16/100	40	16	100	36	44	15114	1,580
23.306.40.16/130	40	16	130	36	44	15114	1,830
23.306.40.16/160	40	16	160	36	44	15114	2,100
23.306.40.18/100	40	18	100	38	46	15114	1,600
23.306.40.18/130	40	18	130	38	46	15114	1,900
23.306.40.18/160	40	18	160	38	46	15114	2,700
23.306.40.20/100	40	20	100	44	50	15116	1,710
23.306.40.20/130	40	20	130	44	50	15116	2,070
23.306.40.20/160	40	20	160	44	50	15018	2,490
23.306.40.25/130	40	25	130	50	50	15018	2,240
23.306.40.25/160	40	25	160	50	50	15018	2,660
23.306.50.06/130	50	6	130	22	28	15006	3,970
23.306.50.06/160	50	6	160	22	33	15006	4,140
23.306.50.06/200	50	6	200	22	36	15006	4,440
23.306.50.08/130	50	8	130	24	30	15008	3,950
23.306.50.08/160	50	8	160	24	35	15008	4,240
23.306.50.08/200	50	8	200	24	38	15008	4,530
23.306.50.10/130	50	10	130	30	38	15010	4,250
23.306.50.10/160	50	10	160	30	39	15010	4,470
23.306.50.10/200	50	10	200	30	43	15010	4,900

Reference Bezeichnung	K ISO	d1 H4	L	D	D1	2x 	
23.306.50.12/130	50	12	130	32	40	15012	4,270
23.306.50.12/160	50	12	160	32	43	15012	4,570
23.306.50.12/200	50	12	200	32	46	15012	4,980
23.306.50.14/130	50	14	130	32	40	15012	4,230
23.306.50.14/160	50	14	160	32	44	15012	4,490
23.306.50.14/200	50	14	200	32	48	15012	5,100
23.306.50.16/130	50	16	130	36	44	15114	4,340
23.306.50.16/160	50	16	160	36	44	15114	4,610
23.306.50.16/200	50	16	200	36	50	15114	5,230
23.306.50.18/130	50	18	130	38	46	15114	4,390
23.306.50.18/160	50	18	160	38	46	15114	4,770
23.306.50.18/200	50	18	200	38	52	15114	5,340
23.306.50.20/130	50	20	130	44	50	15116	4,640
23.306.50.20/160	50	20	160	44	50	15116	4,950
23.306.50.20/200	50	20	200	44	55	15116	5,650
23.306.50.25/130	50	25	130	50	56	4 x 15018	4,800
23.306.50.25/160	50	25	160	50	60	4 x 15018	5,440
23.306.50.25/200	50	25	200	50	64	4 x 15018	6,270
23.306.50.32/200	50	32	200	58	72	4 x 15120	7,050



I



**Characteristics:**

Combined end mills adaptors type Weldon / Whistle-Notch.

JIS B 6339-BT

For tools with cylindrical shank and tightening inclined flat DIN 1835-B+E. Similar to DIN 69871 - Form AD+B

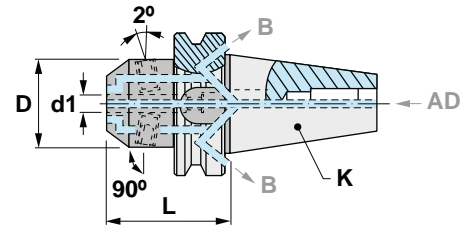

Coolant distribution through the centre or through the flange of the tool.

**Eigenschaften:**



Kombi-Aufnahme Typ Weldon/ Whistle-Notch. JIS B 6339-BT

Für Werkzeuge mit zylindrischem Schaft und geneigter Spannfläche DIN 1835-B+E.

Ähnlich wie DIN 69871 - Form AD+B

Kühlmittel-Verteilung durch die Zentralbohrung oder durch den Bund.

## 23.307

Reference Bezeichnung	K ISO	d1 H4	L	D		2x 	
23.307.40.06	40	6	50	25	19005	15106	1,080
23.307.40.08	40	8	50	28	19106	15108	1,130
23.307.40.10	40	10	63	35	19008	15110	1,200
23.307.40.12	40	12	63	42	19110	15212	1,280
23.307.40.14	40	14	63	44	19110	15212	1,290
23.307.40.16	40	16	63	48	19012	15314	1,440
23.307.40.18	40	18	63	50	19012	15314	1,360
23.307.40.20	40	20	63	52	19016	15216	1,380
23.307.40.25	40	25	90	65	19020	4 x 15218	2,190
23.307.40.32	40	32	100	72	19020	4 x 15220	2,700
23.307.50.06	50	6	63	25	19005	15106	3,850
23.307.50.08	50	8	63	28	19106	15108	3,690
23.307.50.10	50	10	65	35	19008	15110	3,950
23.307.50.12	50	12	80	42	19110	15212	3,880
23.307.50.14	50	14	80	44	19110	15212	3,910
23.307.50.16	50	16	80	48	19012	15314	3,990
23.307.50.18	50	18	80	50	19012	15314	4,290
23.307.50.20	50	20	80	52	19016	15216	4,050
23.307.50.25	50	25	100	65	19020	4 x 15218	4,950
23.307.50.32	50	32	105	72	19020	4 x 15220	5,310
23.307.50.40	50	40	120	90	19020	4 x 15220	6,770



Characteristics:  
Mill adaptors.  
JIS B 6339-BT  
For frontal end mill support  
screwed shanks.  
Similar to DIN 69871 - Form AD+B

Eigenschaften:  
Spannfutter.  
JIS B 6339-BT  
Für Einschraubfräser.  
Ähnlich wie DIN 69871 - Form AD+B

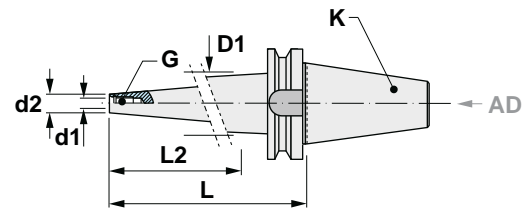

## 23.315

Reference Bezeichnung	K ISO	L	d1	G	d2	L2	D1	⚖️ Kg
23.315.40.10/055	40	55	10,5	M10	18	25	20	1,040
23.315.40.10/080	40	80	10,5	M10	18	50	23	1,110
23.315.40.10/130	40	130	10,5	M10	18	100	29	1,350
23.315.40.12/055	40	55	12,5	M12	21	25	24	1,100
23.315.40.12/080	40	80	12,5	M12	21	50	26	1,140
23.315.40.12/130	40	130	12,5	M12	21	100	32	1,430
23.315.40.16/055	40	55	17,0	M16	29	25	32	1,100
23.315.40.16/080	40	80	17,0	M16	29	50	35	1,200
23.315.40.16/130	40	130	17,0	M16	29	100	40	1,710
23.315.50.12/090	50	90	12,5	M12	21	50	26	4,100
23.315.50.12/140	50	140	12,5	M12	21	100	32	4,150
23.315.50.12/190	50	190	12,5	M12	21	150	37	4,480
23.315.50.16/090	50	90	17,0	M16	29	50	35	3,950
23.315.50.16/140	50	140	17,0	M16	29	100	40	4,360
23.315.50.16/190	50	190	17,0	M16	29	150	45	4,950



**Characteristics:**  
Antivibratory end mill adaptors.  
JIS B 6339-BT  
For frontal end mill support screwed shanks.  
Manufactured with materials and mechanisms having antivibration properties. Standard and extra long lengths, suitable for moulding and special manufactures.

**PRE-BALANCED**  
ISO-40: 15.000 r.p.m. G-6,3  
ISO-50: 10.000 r.p.m. G-6,3

**Eigenschaften:**  
Schwingungsgedämpfte Aufsteckfräsdorne für Einschraubfräser. JIS B 6339-BT  
Hergestellt mit schwingungsdämpfenden Materialien und Mechanismen.  
Standard und extralange Ausführungen sind für Werkzeug- und Formenbau besonders geeignet.

**VORGEWUCHTET**  
ISO-40: 15.000 r.p.m. G-6,3  
ISO-50: 10.000 r.p.m. G-6,3

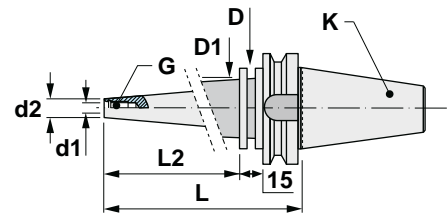

## A20.315

Reference Bezeichnung	K ISO	L2	D1	L	D	d1	G	d2	 Kg
A20.315.40.10/200	40	158	35	200	50	10,5	M10	18	1,970
A20.315.40.10/250	40	208	40	250	50	10,5	M10	18	2,260
A20.315.40.10/300	40	258	45	300	50	10,5	M10	18	2,820
A20.315.40.12/200	40	158	38	200	50	12,5	M12	21	2,000
A20.315.40.12/250	40	208	43	250	50	12,5	M12	21	2,490
A20.315.40.12/300	40	258	44	300	50	12,5	M12	21	3,130
A20.315.40.16/200	40	158	43	200	50	17,0	M16	29	2,490
A20.315.40.16/250	40	208	44	250	50	17,0	M16	29	2,810
A20.315.40.16/300	40	258	47	300	50	17,0	M16	29	3,450
A20.315.50.12/250	50	197	42	250	80	12,5	M12	21	5,250
A20.315.50.12/300	50	247	47	300	80	12,5	M12	21	5,910
A20.315.50.12/400	50	347	57	400	80	12,5	M12	21	7,580
A20.315.50.16/300	50	247	55	300	80	17,0	M16	29	6,800
A20.315.50.16/400	50	347	65	400	80	17,0	M16	29	9,000
A20.315.50.16/500	50	447	76	500	80	17,0	M16	29	12,000

**Characteristics:**

Collet chucks for DIN 6388 collets.  
JIS B 6339-BT  
For tools with cylindrical shank  
DIN 1835-B.

\* Ball bearing nut, see page: I220

**\* SUPPLIED WITHOUT WRENCH**

**Eigenschaften:**



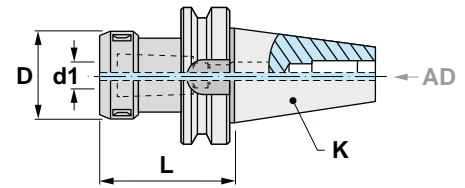

Spannzangenfutter für Spannzangen  
DIN6388. JIS B 6339-BT  
Für Werkzeuge mit zylindrischem  
Schaft DIN 1835-B.

\* Für Kugellager-Mutter, siehe Seite: I220

**\* LIEFERUNG OHNE SCHLÜSSEL**



## 20.353

Reference Bezeichnung	K ISO	L	d1	D				
20.353.30.16	30	65	2-16	43	43316	50116	19216	0,650
20.353.30.25	30	70	3-25	60	43325	50125	19216	0,830
20.353.40.16	40	70	2-16	43	43316	50116	19216	1,210
20.353.40.16/120	40	120	2-16	43	43316	50116	19216	1,580
20.353.40.25	40	70	3-25	60	43325	50125	19224	1,320
20.353.40.25/120	40	120	3-25	60	43325	50125	19224	1,880
20.353.40.32	40	90	4-32	72	43332	50132	19224	1,790
20.353.50.16	50	70	2-16	43	43316	50116	19216	3,850
20.353.50.16/120	50	120	2-16	43	43316	50116	19216	4,170
20.353.50.25	50	85	3-25	60	43325	50125	19224	4,100
20.353.50.25/140	50	140	3-25	60	43325	50125	19224	4,980
20.353.50.32	50	90	4-32	72	43332	50132	19230	4,220

## BXX

 I206-208

Ref. / Bez.

Accessories / Zubehör

BXX

Collets with double slot DIN 6388 - Form B

Spannzangen mit Doppelnut DIN 6388 - Form B





**Characteristics:**  
Strong hold collet chuck for cylindrical collets.  
JIS B 6339-BT

**Eigenschaften:**  
Kraftspannfutter für zylindrische Spannzangen.  
JIS B 6339-BT

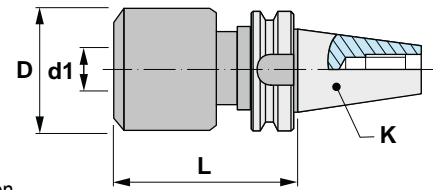

## 20.400

Reference Bezeichnung	K ISO	L	d1	D	
20.400.40.20	40	105	20	54	1,950
20.400.40.32	40	105	32	72	2,550
20.400.50.20	50	105	20	54	3,850
20.400.50.32	50	105	32	72	4,450

### Complements (collets type C) / Zubehör (Spannzangen typ C)

Reference / Bezeichnung	d	D	L
C2006	6	20	55
C2008	8	20	55
C2010	10	20	55
C2012	12	20	55
C2016	16	20	55
C3206	6	32	65
C3208	8	32	65
C3210	10	32	65
C3212	12	32	65
C3216	16	32	65
C3220	20	32	65
C3225	25	32	65

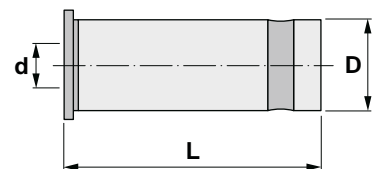

**Characteristics:**

Set of strong hold milling chuck and collets.  
JIS B 6339-BT

**Eigenschaften:**

Satz mit Kraftspannfutter und Spannzangen.  
JIS B 6339-BT

## SET-C20/32

Reference Bezeichnung	JIS	Composition Bestehend aus	
SET-20.40.C20	JIS B 6339-BT	1 x 20.400.40.20 + 5 collets / Spannzangen	4,500
SET-20.40.C32	JIS B 6339-BT	1 x 20.400.40.32 + 7 collets / Spannzangen	6,800
SET-20.50.C32	JIS B 6339-BT	1 x 20.400.50.32 + 7 collets / Spannzangen	9,300





**Characteristics:**

Collet chucks for DIN 6499 (ER) collets.  
JIS B 6339-BT  
For tools with cylindrical shank  
DIN 1835-B.

\* Ball bearing nut, see page: I221

**\* SUPPLIED WITHOUT WRENCH**

**Eigenschaften:**



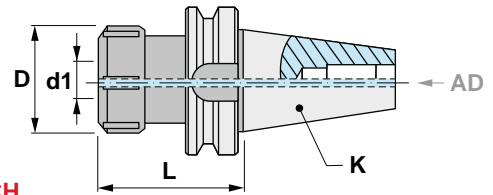

Spannzangenfutter für Spannzangen  
DIN 6499 (ER).  
JIS B 6339-BT  
Für Werkzeuge mit zylindrischem Schaft  
DIN 1835-B.

\* Für Kugellager-Mutter, siehe Seite: I221

**\* LIEFERUNG OHNE SCHLÜSSEL**



## 20.453

Reference Bezeichnung	K ISO		L	d1	D				
20.453.30.16	30	ER16	55	0,5-10	32	45316	50216	19210	0,490
20.453.30.20	30	ER20	55	1-13	35	45320	50220	19212	0,490
20.453.30.25	30	ER25	55	1-16	42	45325	50225	19216	0,520
20.453.30.32	30	ER32	60	2-20	50	45332	50232	19218	0,580
20.453.40.16	40	ER16	70	0,5-10	32	45316	50216	19210	1,130
20.453.40.16/100	40	ER16	100	0,5-10	32	45316	50216	19210	1,230
20.453.40.16/150	40	ER16	150	0,5-10	32	45316	50216	19210	1,400
20.453.40.20	40	ER20	70	1-13	35	45320	50220	19212	1,120
20.453.40.20/100	40	ER20	100	1-13	35	45320	50220	19212	1,320
20.453.40.20/150	40	ER20	150	1-13	35	45320	50220	19212	1,550
20.453.40.25	40	ER25	70	1-16	42	45325	50225	19216	1,200
20.453.40.25/100	40	ER25	100	1-16	42	45325	50225	19216	1,690
20.453.40.25/150	40	ER25	150	1-16	42	45325	50225	19216	1,790
20.453.40.32	40	ER32	70	2-20	50	45332	50232	19222	1,230
20.453.40.32/100	40	ER32	100	2-20	50	45332	50232	19222	2,090
20.453.40.32/150	40	ER32	150	2-20	50	45332	50232	19222	2,180
20.453.40.40	40	ER40	70	3-30	63	45340	50240	19224	1,340
20.453.40.40/150	40	ER40	150	3-30	63	45340	50240	19224	2,280
20.453.50.16/100	50	ER16	100	0,5-10	32	45316	50216	19210	3,840
20.453.50.16/150	50	ER16	150	0,5-10	32	45316	50216	19210	4,080
20.453.50.20/100	50	ER20	100	1-13	35	45320	50220	19212	3,950
20.453.50.20/150	50	ER20	150	1-13	35	45320	50220	19212	4,060
20.453.50.25	50	ER25	70	1-16	42	45325	50225	19216	3,830
20.453.50.25/150	50	ER25	150	1-16	42	45325	50225	19216	4,360
20.453.50.32	50	ER32	70	2-20	50	45332	50232	19222	3,850
20.453.50.32/100	50	ER32	100	2-20	50	45332	50232	19222	4,660
20.453.50.32/150	50	ER32	150	2-20	50	45332	50232	19222	4,530
20.453.50.40	50	ER40	80	3-30	63	45340	50240	19224	4,060
20.453.50.40/150	50	ER40	150	3-30	63	45340	50240	19224	5,240
20.453.50.50	50	ER50	90	10-34	78	45350	50250	19230	4,290

**ERXX** ⓘ I210-212

Reference / Bez.

ERXX



**ERCXX** ⓘ I215-216

Reference / Bez.

ERCXX



**ERTXX** ⓘ I217-218

Reference / Bez.

ERTXX



**40.453..** ⓘ I180

Reference / Bez.

40.453..



**40.455..** ⓘ I181

Reference / Bez.

40.455..





**Characteristics:**

Collet chucks for DIN 6499 (ER) collets. JIS B 6339-BT  
For tools with cylindrical shank DIN 1835-B.  
Similar to DIN 69871 - Form AD+B  
\* Ball bearing nut, see page: I221

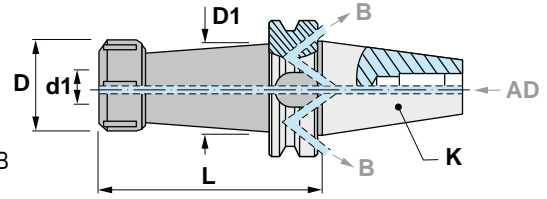





**\* SUPPLIED WITHOUT WRENCH**

**Eigenschaften:**

Spannzangenfutter für Spannzangen  
DIN 6499 (ER). JIS B 6339-BT.  
Für Werkzeuge mit zylindrischem  
Schaft DIN 1835-B.  
Ähnlich wie DIN 69871 - Form AD+B  
\* Für Kugellager-Mutter, siehe Seite: I221

**\* LIEFERUNG OHNE SCHLÜSSEL**

# 23.453

Reference Bezeichnung	K ISO		L	d1	D	D1				
23.453.40.16	40	ER16	70	0,5-10	32	-	45316	50216	19210	1,140
23.453.40.16/100	40	ER16	100	0,5-10	32	28	45316	50216	19210	1,310
23.453.40.16/150	40	ER16	150	0,5-10	32	28	45316	50216	19210	1,390
23.453.40.20	40	ER20	70	1-13	35	-	45320	50220	19212	1,140
23.453.40.20/100	40	ER20	100	1-13	35	34	45320	50220	19212	1,480
23.453.40.20/150	40	ER20	150	1-13	35	34	45320	50220	19212	1,520
23.453.40.25	40	ER25	70	1-16	42	-	45325	50225	19216	1,200
23.453.40.25/150	40	ER25	150	1-16	42	42	45325	50225	19216	1,850
23.453.40.32	40	ER32	70	2-20	50	-	45332	50232	19222	1,230
23.453.40.32/150	40	ER32	150	2-20	50	50	45332	50232	19222	2,100
23.453.40.40	40	ER40	70	3-30	63	-	45340	50240	19224	1,340
23.453.40.40/150	40	ER40	150	3-30	63	63	45340	50240	19224	2,430
23.453.50.16/100	50	ER16	100	0,5-10	32	28	45316	50216	19210	3,870
23.453.50.16/150	50	ER16	150	0,5-10	32	28	45316	50216	19210	4,170
23.453.50.20/100	50	ER20	100	1-13	35	28	45320	50220	19212	3,910
23.453.50.20/150	50	ER20	150	1-13	35	28	45320	50220	19212	4,360
23.453.50.25	50	ER25	70	1-16	42	-	45325	50225	19216	3,810
23.453.50.25/150	50	ER25	150	1-16	42	42	45325	50225	19216	4,320
23.453.50.32	50	ER32	70	2-20	50	-	45332	50232	19222	3,810
23.453.50.32/100	50	ER32	100	2-20	50	50	45332	50232	19222	4,660
23.453.50.32/150	50	ER32	150	2-20	50	50	45332	50232	19222	5,190
23.453.50.40	50	ER40	80	3-30	63	-	45340	50240	19224	3,950
23.453.50.40/150	50	ER40	150	3-30	63	63	45340	50240	19224	5,180
23.453.50.50	50	ER50	90	10-34	78	-	45350	50250	19230	4,230

**ERXX** ⓘ I210-212  
Reference / Bez.  
ERXX 

**ERCXX** ⓘ I215-216  
Reference / Bez.  
ERCXX 

**ERTXX** ⓘ I217-218  
Reference / Bez.  
ERTXX 

**40.453..** ⓘ I180  
Reference / Bez.  
40.453.. 

**40.455..** ⓘ I181  
Reference / Bez.  
40.455.. 



**Characteristics:**  
Long collet chuck for DIN 6499 (ER) collets.  
JIS B 6339-BT  
For tools with cylindrical shank.  
With "mini" collet nut.

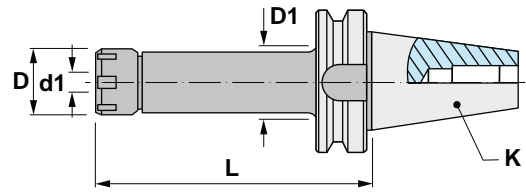

**\* SUPPLIED WITHOUT WRENCH**

**Eigenschaften:**  
Lange Spannzangenfutter für Spannzangen DIN 6499 (ER).  
JIS B 6339-BT  
Für Werkzeuge mit zylindrischem Schaft.  
Mit "Mini"-Spannmutter.

**\* LIEFERUNG OHNE SCHLÜSSEL**

## 20.455

Reference Bezeichnung	K ISO		L	d1	D	D1				
20.455.40.16/100	40	ER16	100	0,5-10	22	22	45516	50916	19210	1,230
20.455.40.16/130	40	ER16	130	0,5-10	22	22	45516	50916	19210	1,310
20.455.40.16/160	40	ER16	160	0,5-10	22	22	45516	50916	19210	1,390
20.455.40.20/100	40	ER20	100	1-13	28	28	45520	50920	19212	1,350
20.455.40.20/160	40	ER20	160	1-13	28	28	45520	50920	19212	1,580
20.455.40.25/100	40	ER25	100	1-16	35	35	45525	50925	19216	1,600
20.455.40.25/160	40	ER25	160	1-16	35	35	45525	50925	19216	1,990

### ERXX

 I210-212

Ref. / Bez.      Accessories / Zubehör

ERXX      Collets with double slot DIN 6499 - Form B (ER)  
Spannzangen mit Doppelnut DIN 6499 - Form B (ER)



### ERCXX

 I215-216

Ref. / Bez.      Accessories / Zubehör

ERCXX      Sealed collets DIN 6499 (ER)  
Abgedichtete Spannzangen DIN 6499 (ER)



### ERTXX

 I217-218

Ref. / Bez.      Accessories / Zubehör

ERTXX      Collets DIN 6499 - Form Mexin (ER)  
Spannzangen DIN 6499 - Form Mexin (ER)





**Characteristics:**  
Mechanical collet chuck with high tightening torque and precision.  
JIS B 6339-BT  
For DIN 6499 (ER) collets.  
The alternative to hydraulic or other systems. With central coolant supply.

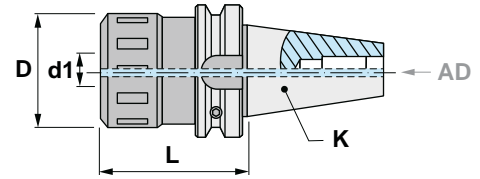

**\* SUPPLIED WITH WRENCH**

**Eigenschaften:**  
Mechanisches Spannzangenfutter mit hohem Anzugsmoment.  
JIS B 6339-BT  
Für Spannzangen DIN 6499 (ER).  
Die Alternative zu hydraulischen und anderen Systemen. Mit Innenkühlung.

**\* LIEFERUNG MIT SCHLÜSSEL**

## 20.457

Reference Bezeichnung	K ISO		L	d1	D				
20.457.40.32	40	ER32	80	2-20	54	45732	50704	19006	1,420
20.457.50.32	50	ER32	110	2-20	54	45732	50704	19006	4,610
20.457.50.40	50	ER40	120	3-30	65	45740	50706	19010	5,500

### ERXX

 I210-212

Ref. / Bez.      Accessories / Zubehör

ERXX      Collets with double slot DIN 6499 - Form B (ER)  
Spannzangen mit Doppelnut DIN 6499 - Form B (ER)



### ERCXX

 I215-216

Ref. / Bez.      Accessories / Zubehör

ERCXX      Sealed collets DIN 6499 (ER)  
Abgedichtete Spannzangen DIN 6499 (ER)





**Characteristics:**

Mechanical collet chuck with high tightening torque and precision.  
JIS B 6339-BT  
For DIN 6499 (ER) collets.  
The alternative to hydraulic or other systems. With central coolant supply.

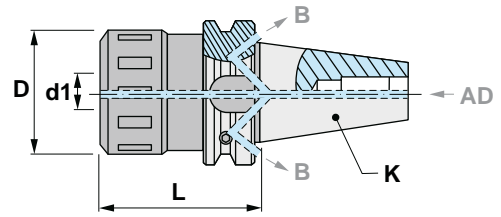





**\* SUPPLIED WITH WRENCH**

**Eigenschaften:**

Mechanisches Spannzangenfutter mit hohem Anzugsmoment.  
JIS B 6339-BT  
Für Spannzangen DIN 6499 (ER).  
Die Alternative zu hydraulischen und anderen Systemen. Mit Innenkühlung.

**\* LIEFERUNG MIT SCHLÜSSEL**

## 23.457

Reference Bezeichnung	K ISO		L	d1	D				
23.457.40.32	40	ER32	80	2-20	54	45732	50704	19006	1,750
23.457.50.32	50	ER32	110	2-20	54	45732	50704	19006	4,380
23.457.50.40	50	ER40	120	3-30	65	45740	50706	19010	5,470

### ERXX

 I210-212

Ref. / Bez.      Accessories / Zubehör

ERXX      Collets with double slot DIN 6499 - Form B (ER)  
Spannzangen mit Doppelnut DIN 6499 - Form B (ER)



### ERCXX

 I215-216

Ref. / Bez.      Accessories / Zubehör

ERCXX      Sealed collets DIN 6499 (ER)  
Abgedichtete Spannzangen DIN 6499 (ER)





Characteristics:  
Blank adaptors.  
JIS B 6339-BT

Eigenschaften:  
Rohlinge.  
JIS B 6339-BT

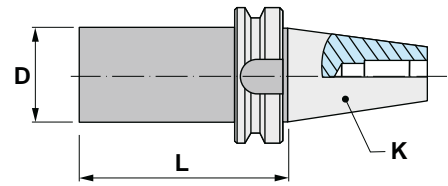

## 20.470

Reference Bezeichnung	K ISO	D	L	
20.470.30.40	30	40,5	160	2,170
20.470.40.63/250	40	63,5	250	6,570
20.470.50.95/315	50	95,5	315	19,000



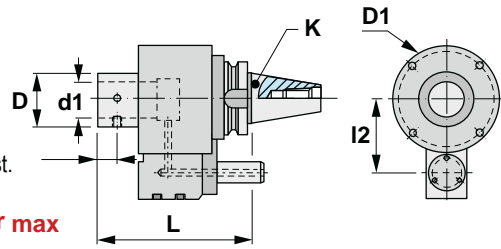

**Characteristics:**  
Cooling fluid supply unit.  
JIS B 6339-BT similar to DIN 6359  
For tools with cylindrical shank  
DIN 1835-B/E.  
\* Other sizes are manufactured on request.



**rpm max 4.000 min. -1 ▫ 25 bar max**

**Eigenschaften:**  
Drehverteiler für Innenkühlung.  
JIS B 6339-BT ähnlich wie DIN 6359.  
Für Werkzeuge mit zylindrischem  
Schaft DIN 1835-B/E.  
\* Andere Größen werden auf Anfrage hergestellt.

## 20.512

Reference Bezeichnung	K ISO	d1 G6	L	D	D1	I1	I2*		
20.512.40.25	40	25	152	45	95	15	65	14116	5,780
20.512.40.32	40	32	152	48	95	16	65	14116	5,640
20.512.50.32	50	32	152	48	110	16	80	14116	8,100
20.512.50.40	50	40	166	58	110	17	80	14116	8,140

### Complements of 512 group / Zubehör von gruppe 512

Reference / Bezeichnung	D	d	D1	L
512.25.16	25	16	33	60
512.25.20		20	33	60
512.32.16	32	16	40	60
512.32.20		20	40	60
512.32.25		25	40	60
512.40.16	40	16	48	60
512.40.20		20	48	60
512.40.25		25	48	60
512.40.32		32	48	60
512.00.00				

512..

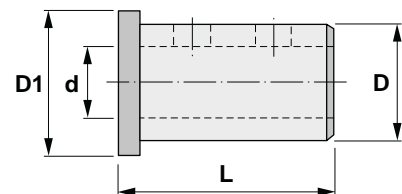

512.00.00

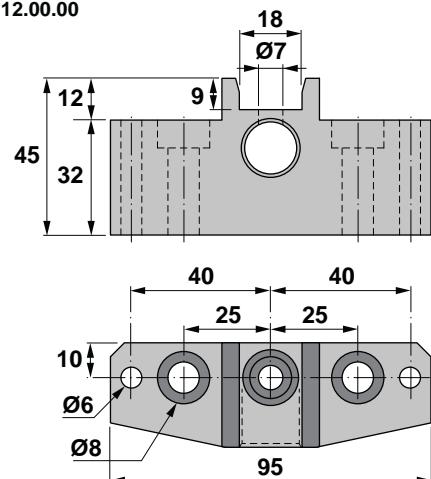

**Characteristics:**

Tapping head with axial compensation.

JIS B 6339-BT

For DIN 6499 (ER) collets and with central coolant supply.

Compensation in compression (C) and tension (T). Compression can be blocked by turning the rear ring (A). Control of threading depth.

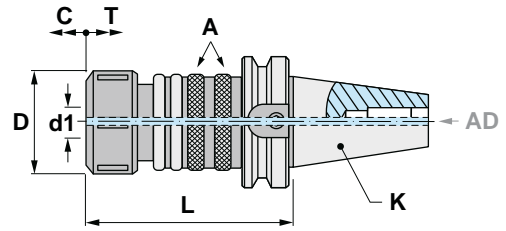



**\* SUPPLIED WITH WRENCH****Eigenschaften:**

Gewindeschneidfutter mit Längenausgleich JIS B 6339-BT.

Befestigung mit Spannzangen 6499 (ER) und mit Innenkühlung.

Ausgleich der Kompression (C) und der Traktion (T). Die Kompression kann mit dem Ring (A) blockiert werden. Kontrolle der Gewindetiefe.

**\* LIEFERUNG MIT SCHLÜSSEL****20.610**

Reference Bezeichnung	K ISO			d1	L	D	C	T			
20.610.30.16	30	ER16	M3-M12	99	28	5,5	6,0	45316	50216	0,580	
20.610.40.16	40	ER16	M3-M12	100	28	5,5	6,0	45316	50216	1,560	
20.610.40.25	40	ER25	M4-M20	125	42	10,5	7,5	45325	50225	2,170	
20.610.40.40	40	ER40	M8-M33	141	63	10,0	10,0	45340	50240	3,440	
20.610.50.16	50	ER16	M3-M12	100	28	5,5	6,0	45316	50216	4,230	
20.610.50.25	50	ER25	M4-M20	134	42	10,5	7,5	45325	50225	4,960	
20.610.50.40	50	ER40	M8-M33	150	63	10,0	10,0	45340	50240	6,230	

**ERXX**
 I210-212

Ref. / Bez.	Accessories / Zubehör
ERXX	Collets with double slot DIN 6499 - Form B (ER) Spannzangen mit Doppelnut DIN 6499 - Form B (ER)

**ERCXX**
 I215-216

Ref. / Bez.	Accessories / Zubehör
ERCXX	Sealed collets DIN 6499 (ER) Abgedichtete Spannzangen DIN 6499 (ER)

**ERTXX**
 I217-218

Ref. / Bez.	Accessories / Zubehör
ERTXX	Collets DIN 6499 - Form Mexin (ER) Spannzangen DIN 6499 - Form Mexin (ER)

**40.453..**
 I180

Ref. / Bez.	Accessories / Zubehör
40.453..	Collet chucks for DIN 6499 (ER) collets Spannzangenfutter für DIN 6499 (ER) Spannzangen

**40.455..**
 I181

Ref. / Bez.	Accessories / Zubehör
40.455..	Long collet chucks for DIN 6499 (ER) collets Lange Spannzangenfutter für DIN 6499 (ER) Spannzangen





**Characteristics:**  
Tapping head with axial compensation.  
JIS B 6339-BT  
For DIN 6499 (ER) collets and with central coolant supply.  
Compensation in compression (C) and tension (T). Compression can be blocked by turning the rear ring (A). Control of threading depth.

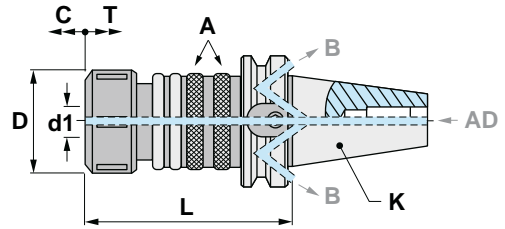

**\* SUPPLIED WITH WRENCH**

**Eigenschaften:**  
Gewindeschneidfutter mit Längenausgleich JIS B 6339-BT.  
Befestigung mit Spannzangen 6499 (ER) und mit Innenkühlung.  
Ausgleich der Kompression (C) und der Traktion (T). Die Kompression kann mit dem Ring (A) blockiert werden. Kontrolle der Gewindetiefe.

**\* LIEFERUNG MIT SCHLÜSSEL**

**23.610**

Reference Bezeichnung	K ISO			d1	L	D	C	T			
23.610.40.16	40	ER16	M3-M12	100	28	5,5	6,0	45316	50216	1,540	
23.610.40.25	40	ER25	M4-M20	125	42	10,5	7,5	45325	50225	2,170	
23.610.40.40	40	ER40	M8-M33	141	63	10,0	10,0	45340	50240	3,440	
23.610.50.16	50	ER16	M3-M12	100	28	5,5	6,0	45316	50216	4,300	
23.610.50.25	50	ER25	M4-M20	134	42	10,5	7,5	45325	50225	4,960	
23.610.50.40	50	ER40	M8-M33	150	63	10,0	10,0	45340	50240	6,230	

**ERXX**

I210-212

Ref. / Bez.      Accessories / Zubehör

ERXX      Collets with double slot DIN 6499 - Form B (ER)  
Spannzangen mit Doppelnut DIN 6499 - Form B (ER)



**ERCXX**

I215-216

Ref. / Bez.      Accessories / Zubehör

ERCXX      Sealed collets DIN 6499 (ER)  
Abgedichtete Spannzangen DIN 6499 (ER)



**ERTXX**

I217-218

Ref. / Bez.      Accessories / Zubehör

ERTXX      Collets DIN 6499 - Form Mexin (ER)  
Spannzangen DIN 6499 - Form Mexin (ER)



**40.453..**

I180

Ref. / Bez.      Accessories / Zubehör

40.453..      Collet chucks for DIN 6499 (ER) collets  
Spannzangenfutter für DIN 6499 (ER) Spannzangen



**40.455..**

I181

Ref. / Bez.      Accessories / Zubehör

40.455..      Long collet chucks for DIN 6499 (ER) collets  
Lange Spannzangenfutter für DIN 6499 (ER) Spannzangen





**Characteristics:**  
Quick change tapping head with axial compensation.  
JIS B 6339-BT  
With Bilz system tap chuck bushings.

Compensation in compression (C) and tension (T).

**Eigenschaften:**  
Gewindeschneid-Schnellwechselfutter mit Längenausgleich.  
JIS B 6339-BT  
Mit Schnellwechseleinsätze Bilz-System.

Ausgleich der Kompression (C) und der Traktion (T).

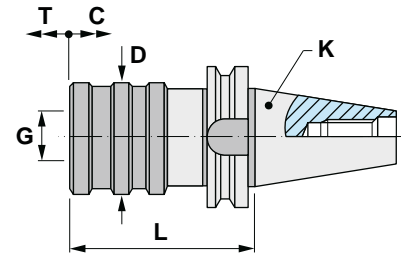

## 20.620

Reference Bezeichnung	K ISO	N <sup>o</sup> Ø	d1	L	D	C	T			
20.620.30.12	30	1 19	M3-M12	63	38	9	9	710XX	750XX	1,000
20.620.40.12	40	1 19	M3-M12	68	38	9	9	710XX	750XX	1,220
20.620.40.20	40	2 31	M8-M20	93	55	15	15	720XX	760XX	1,700
20.620.40.33	40	3 48	M14-M33	138	79	24	24	730XX	770XX	3,710
20.620.50.12	50	1 19	M3-M12	80	38	9	9	710XX	750XX	3,940
20.620.50.20	50	2 31	M8-M20	102	55	15	15	720XX	760XX	4,420
20.620.50.33	50	3 48	M14-M33	135	79	24	24	730XX	770XX	5,630

### 710XX..730XX

I202

Ref. / Bezeichnung

Accessories / Zubehör

710XX..730XX

Quick change adapters without overload clutch  
Schnellwechseleinsätze ohne Sicherheitskupplung



### 750XX..770XX

I203

Ref. / Bezeichnung

Accessories / Zubehör

750XX..770XX

Quick change adapters with overload clutch  
Schnellwechseleinsätze mit Sicherheitskupplung





**Characteristics:**

Quick change tapping head for rigid tapping.  
With Bilz system tap chuck bushings.

With central coolant.

**Eigenschaften:**

Gewindeschneid-Schnellwechselfutter ohne Längenausgleich.

JIS B 6339-BT

Mit Schnellwechseleinsätze Bilz-System.

Mit Innenkühlung.

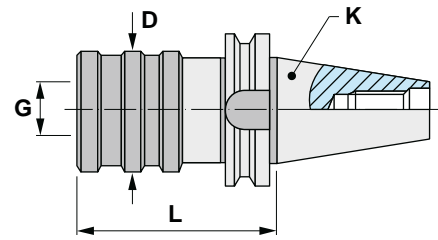

## 20.630

Reference Bezeichnung	K ISO	N <sup>o</sup> . N <sup>o</sup> . Ø	d1	L	D			
20.630.30.12	30	1 19	M3-M12	60	33	710XX	750XX	1,000
20.630.40.12	40	1 19	M3-M12	67	33	710XX	750XX	1,170
20.630.40.20	40	2 31	M8-M20	90	50	720XX	760XX	1,620
20.630.40.33	40	3 48	M14-M33	117	72	730XX	770XX	2,000
20.630.50.12	50	1 19	M3-M12	78	33	710XX	750XX	4,600
20.630.50.20	50	2 31	M8-M20	101	50	720XX	760XX	4,600
20.630.50.33	50	3 48	M14-M33	125	72	730XX	770XX	5,000

### 710XX..730XX

I202

Ref. / Bezeichnung      Accessories / Zubehör

710XX..730XX      Quick change adapters without overload clutch  
Schnellwechseleinsätze ohne Sicherheitskupplung



### 750XX..770XX

I203

Ref. / Bezeichnung      Accessories / Zubehör

750XX..770XX      Quick change adapters with overload clutch  
Schnellwechseleinsätze mit Sicherheitskupplung





Characteristics:  
Test arbors.  
JIS B 6339-BT

Eigenschaften:  
Prüfdorne.  
JIS B 6339-BT

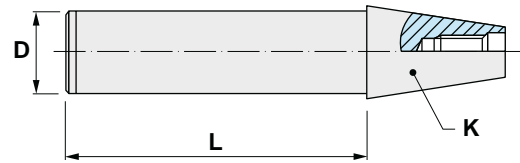

## 20.999

Reference Bezeichnung	K ISO	L	D	
20.999.30	30	300	32	2,160
20.999.40	40	300	40	3,710
20.999.50	50	300	50	7,780

**1 TYPE / TYP**

20.160	20.165	20.180	20.210	20.215	20.216	20.225	20.226	20.290
20.295	20.296	20.300	20.302	20.305	20.353	20.400	20.453	20.455
20.457	20.470	20.512	20.610	20.620	20.630	A20.160	A20.160	A20.315
23.160	23.210	23.215	23.296	23.300	23.302	23.306	23.307	23.315
23.453	23.457	23.610						

**2 DIMENSION / ABMESSUNGEN**

<b>30</b>	<b>40</b>	<b>50</b>	<b>60</b>
-----------	-----------	-----------	-----------

**3 LENGTH / LÄNGE (L)**

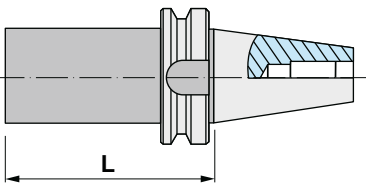
	<hr/> <hr/> <hr/> <hr/> <hr/>
---	-------------------------------

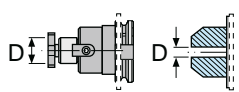
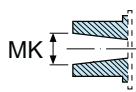
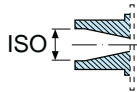
<p>Ø DIAMETER / DURCHMESSER</p> 	<p>MK</p> 	<p>ISO</p> 	<p>COLLET SPANNZANGEN</p>

**NOTES / BEMERKUNGEN:** \_\_\_\_\_

\_\_\_\_\_

\_\_\_\_\_

\_\_\_\_\_