



Modulo Live Tooling
Sistemi di Foratura
e Fresatura
per CNC

Type **TFS31100**

Modulo VDI - Live Tooling

Modulo assiale di foratura e fresatura

Axial drilling and milling live tooling

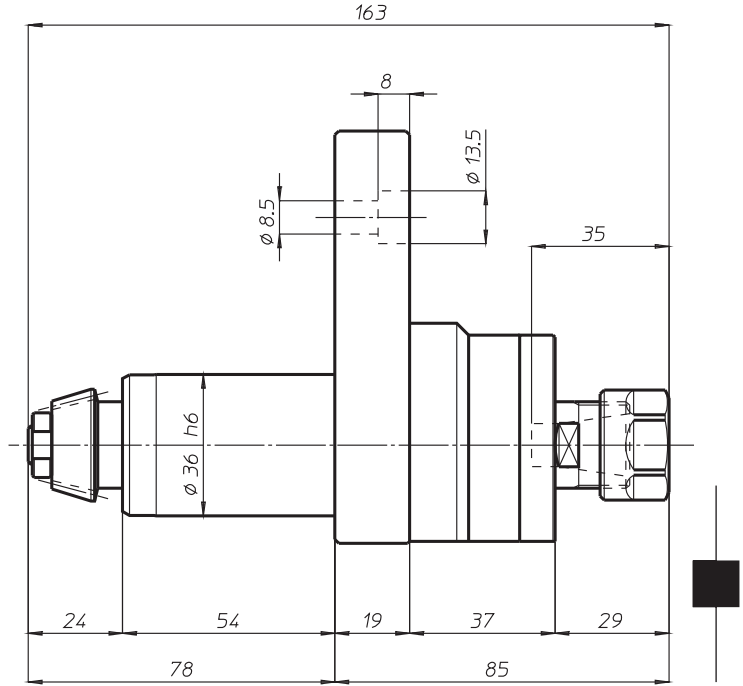
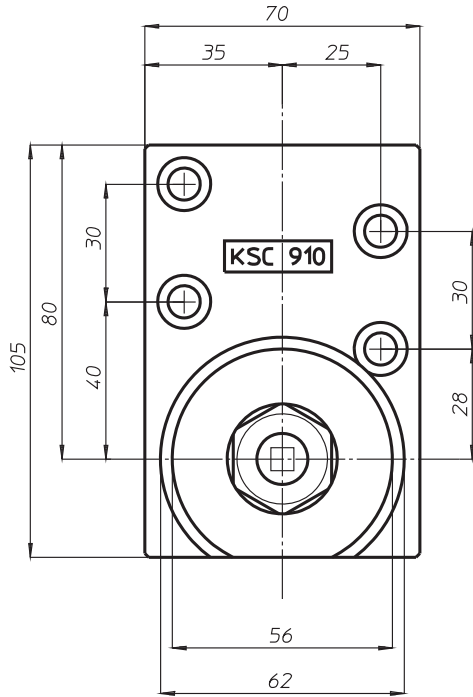

Caratteristiche - Features



Ø 10

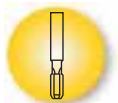

M8

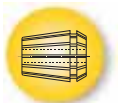

ER16



2



5000



DX



DX

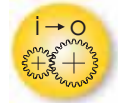

1-1



* NO



.



.



.

Macchina : CINCOM M20-M32

Torretta :

* Solo esterno *Outside only*



Modulo assiale di foratura e fresatura

Axial drilling and milling live tooling

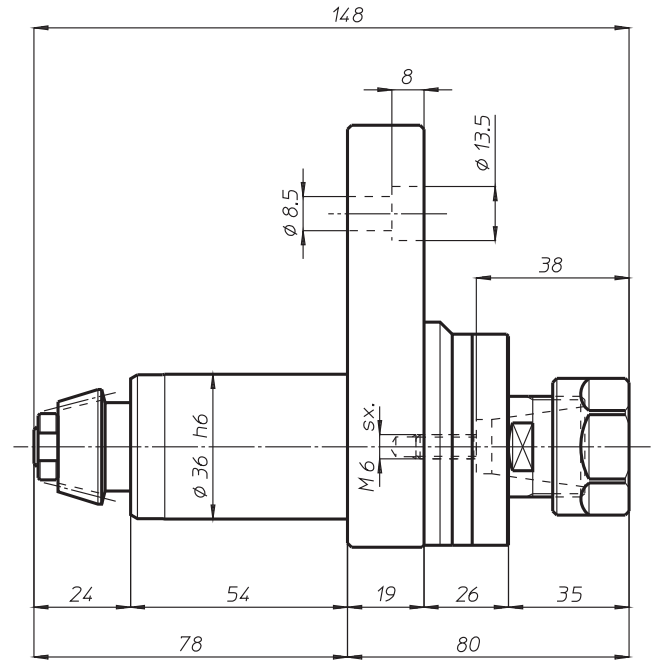
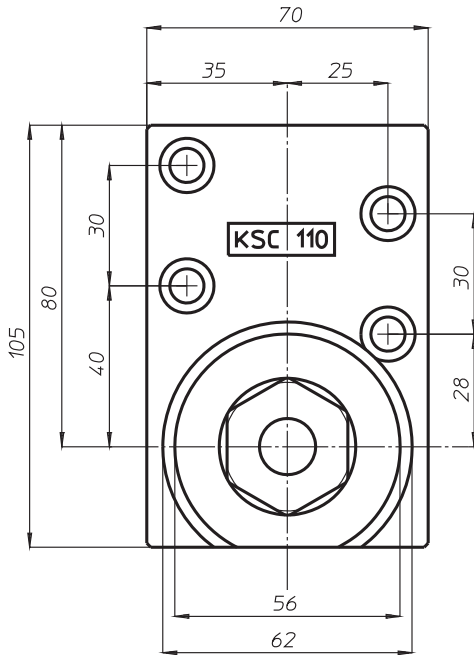

Caratteristiche - Features



Ø 13



M12

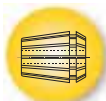

ER20



2



5000



DX



DX

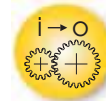

1-1



* NO



.



.



.

Macchina : CINCOM M20-M32

Torretta :

* Solo esterno *Outside only*



Type **TFS39902**

Modulo VDI - Live Tooling

Modulo assiale disassato di foratura e fresatura *Axial offset drilling and milling live tooling*

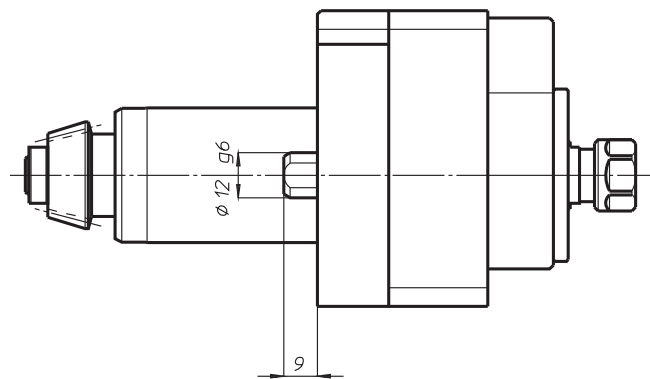
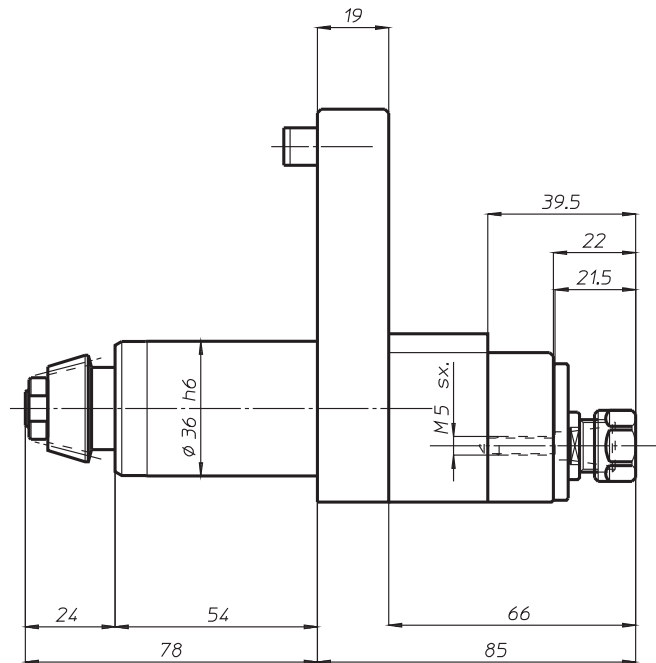
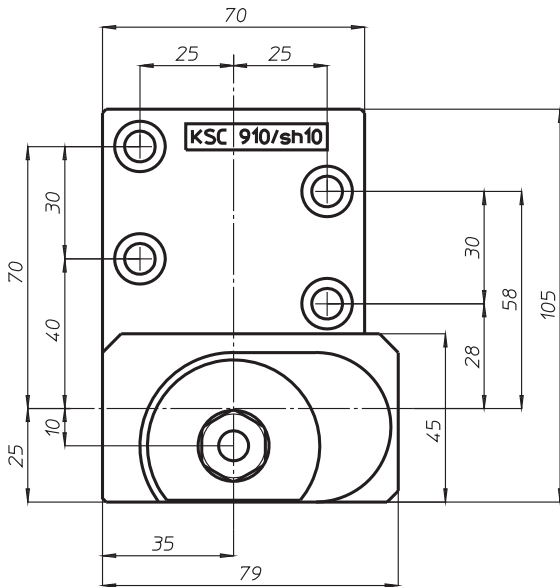

Caratteristiche - Features



ø 7

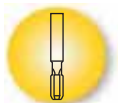

M6

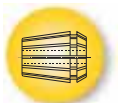

ER11



2.5



5000



DX



DX



1-1



* NO



.



.



.

Macchina : CINCOM M20-M32

Torretta :

* Solo esterno *Outside only*

Modulo assiale disassato di foratura e fresatura

Axial offset drilling and milling live tooling

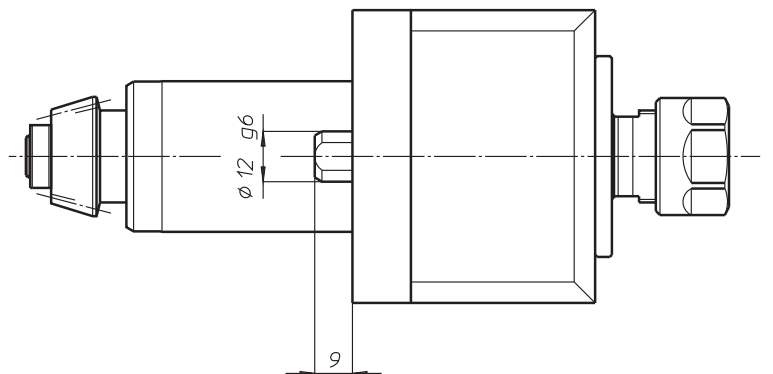
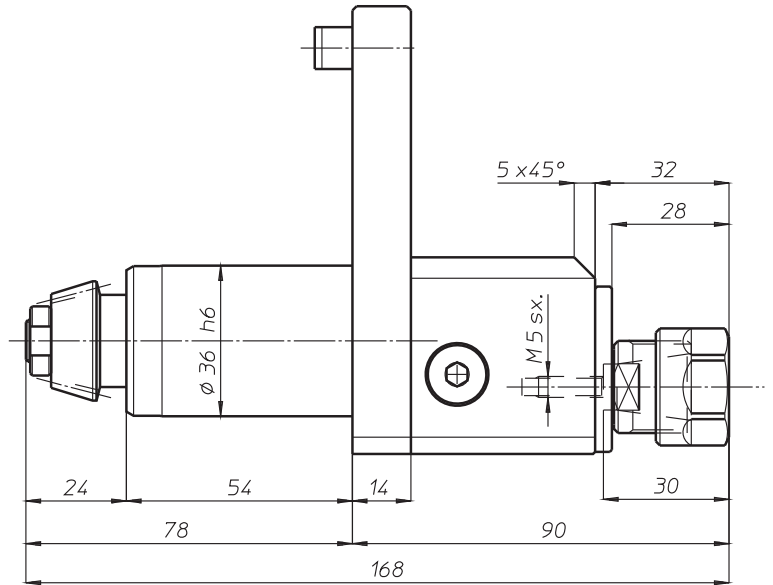
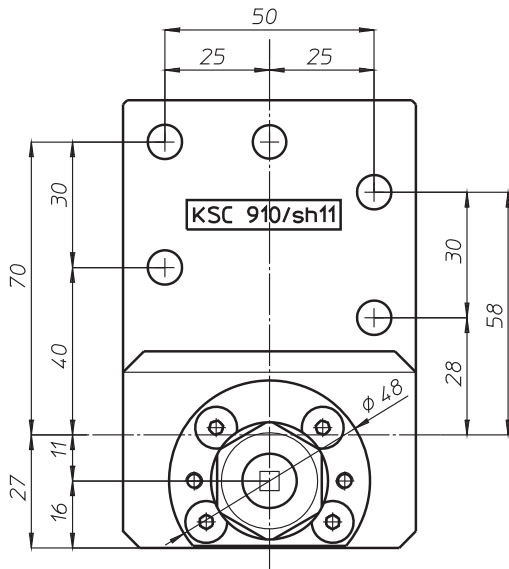

Caratteristiche - Features



Ø 10



M8

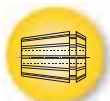

ER16



2.4



5000



DX



DX

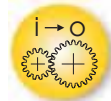

1-1



* NO



.



.



.

Macchina : CINCOM M20-M32

Torretta :

* Solo esterno *Outside only*



Type **TFS48100**

Modulo VDI - Live Tooling

Modulo radiale di foratura e fresatura

Radial drilling and milling live tooling

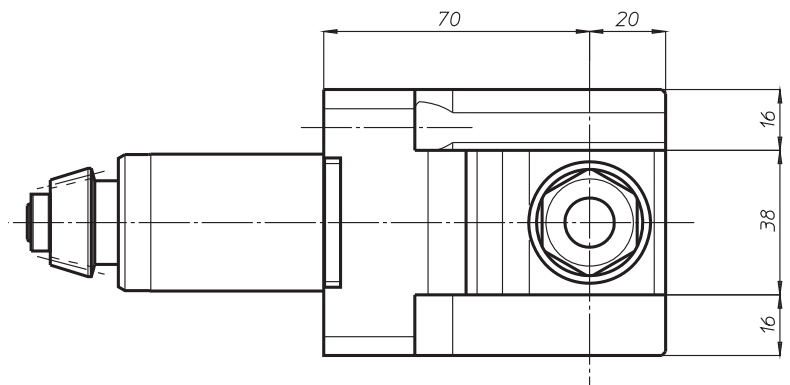
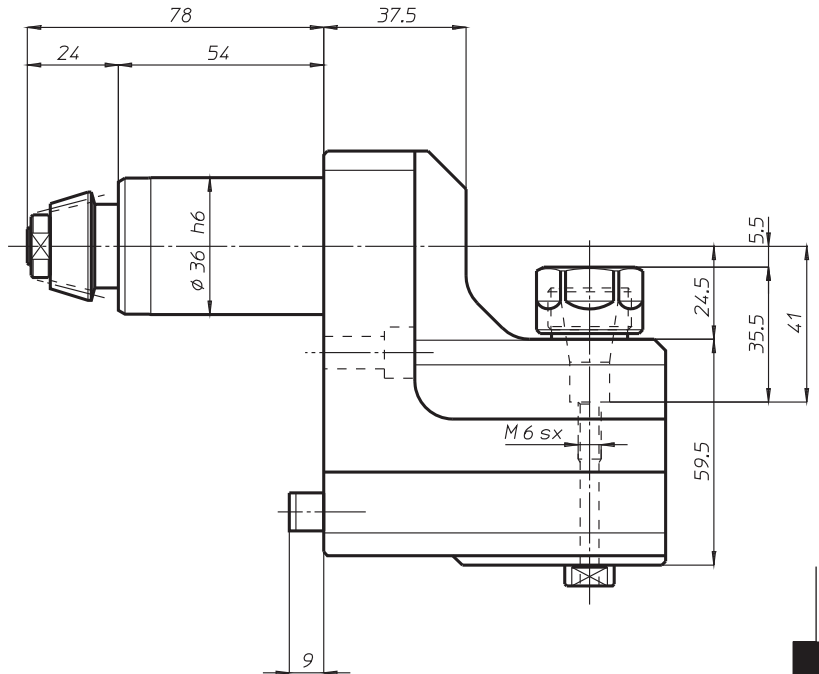
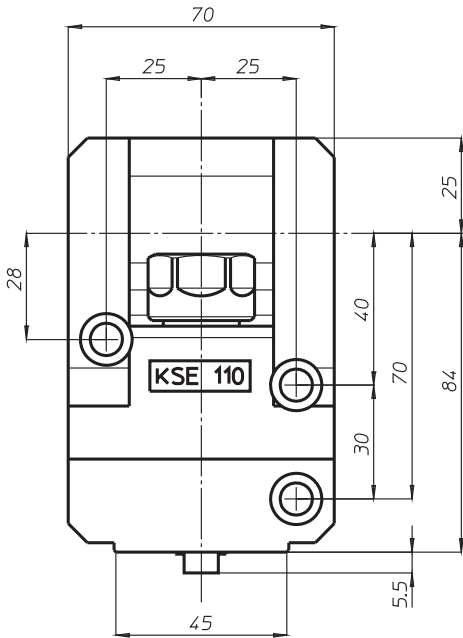

Caratteristiche - Features

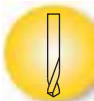

Ø 10



M8

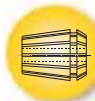

ER16



3.3



5000 RPM



SX



DX

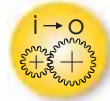

1-1



* NO



.



.



.

Macchina : CINCOM M20-M32

Torretta :

* Solo esterno *Outside only*

Modulo assiale di foratura e fresatura

Axial drilling and milling live tooling

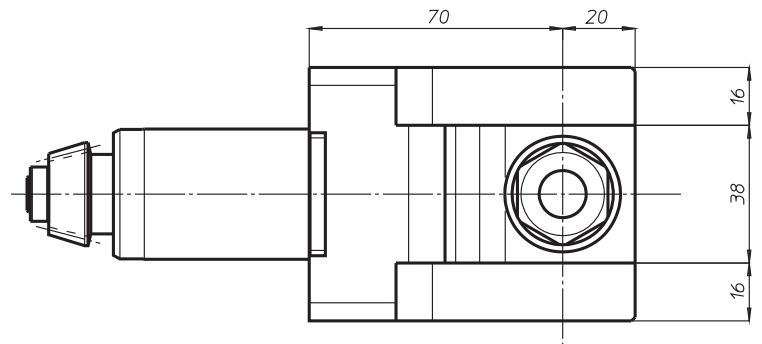
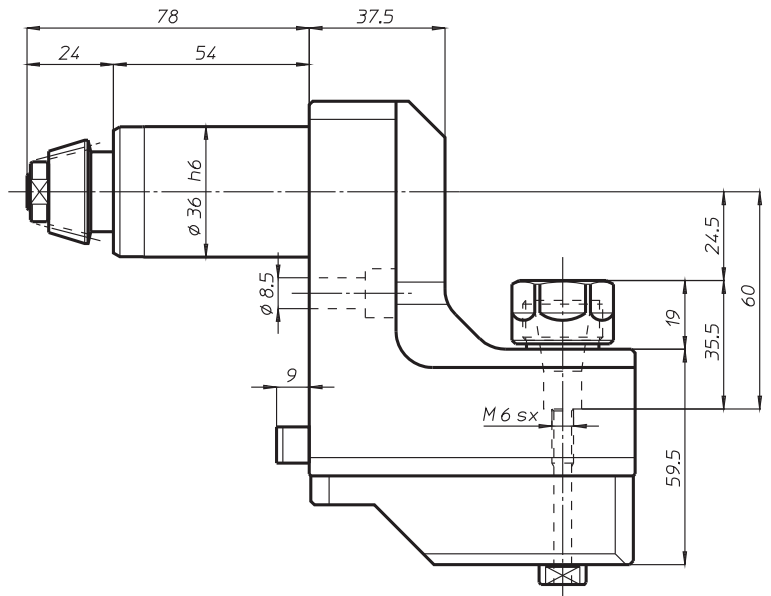
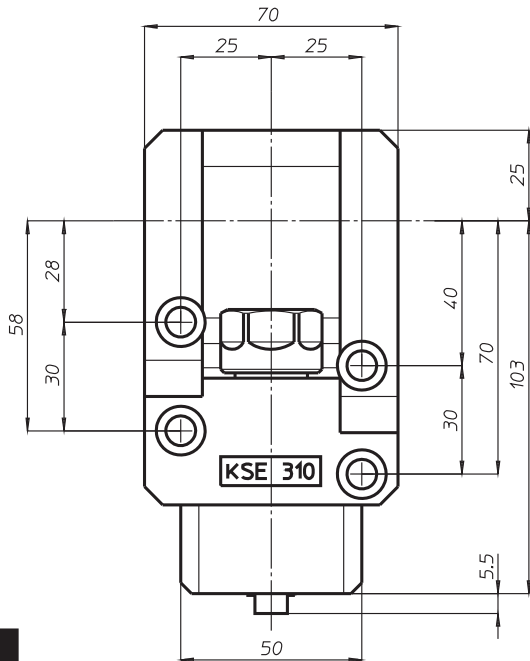

Caratteristiche - Features



$\varnothing 10$



M8

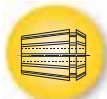

ER16



3.4



5000



SX



DX

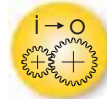

1-1



* NO



.



.



.

Macchina : CINCOM M20-M32

Torretta :

* Solo esterno *Outside only*



Type TFS24705

Modulo VDI - Live Tooling

Modulo radiale di foratura e fresatura

Radial drilling and milling live tooling

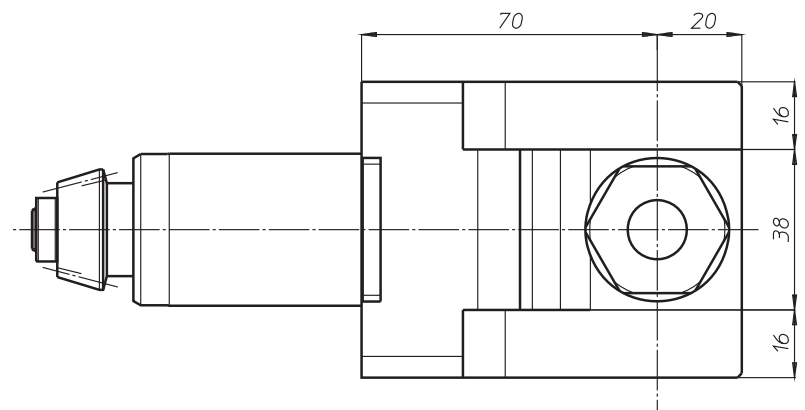
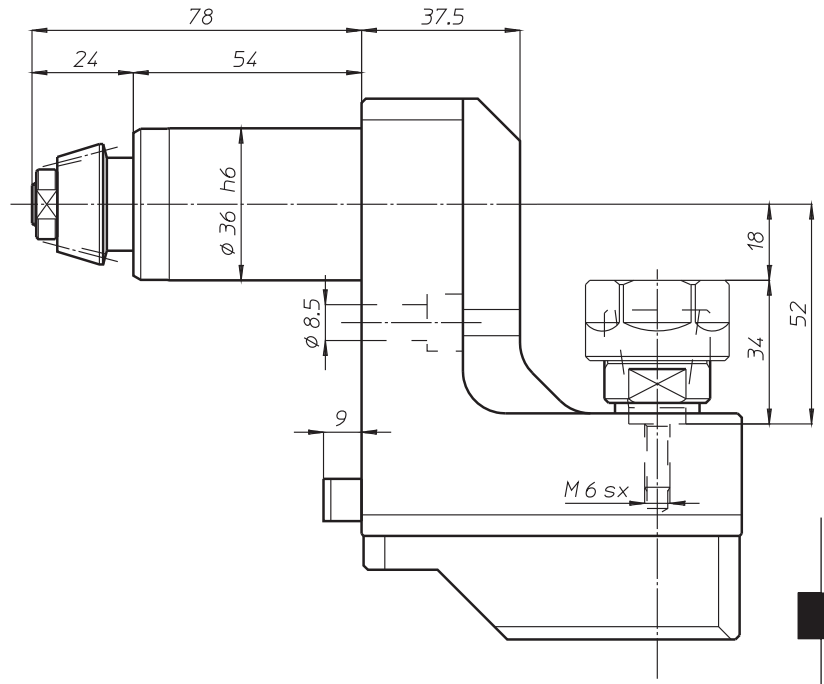
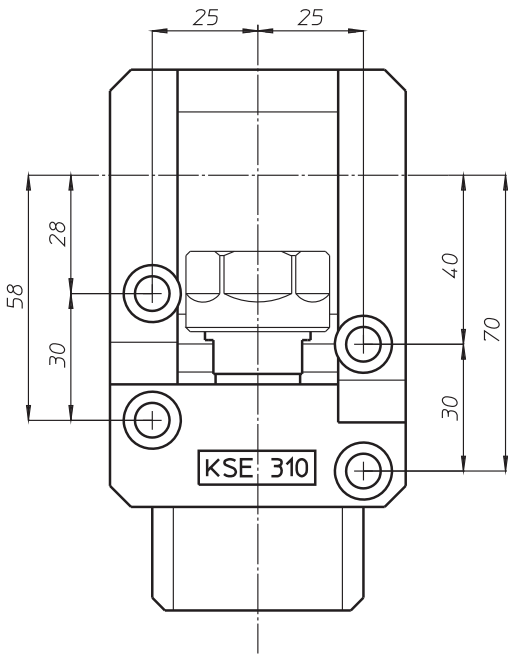

Caratteristiche - Features



$\varnothing 10$

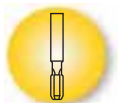

M8

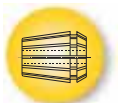

ER20



3.5



5000



SX



DX



1-1



* NO



.



.



.

Macchina : CINCOM M20-M32

Torretta :

* Solo esterno *Outside only*

Modulo radiale bimandrino di foratura e fresatura

Twin radial drilling and milling live tooling

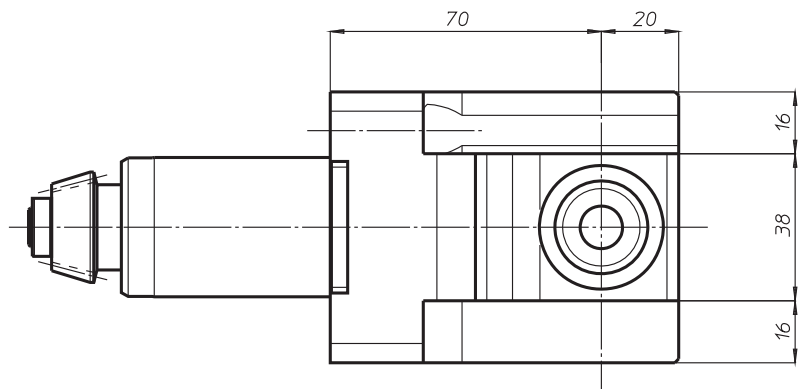
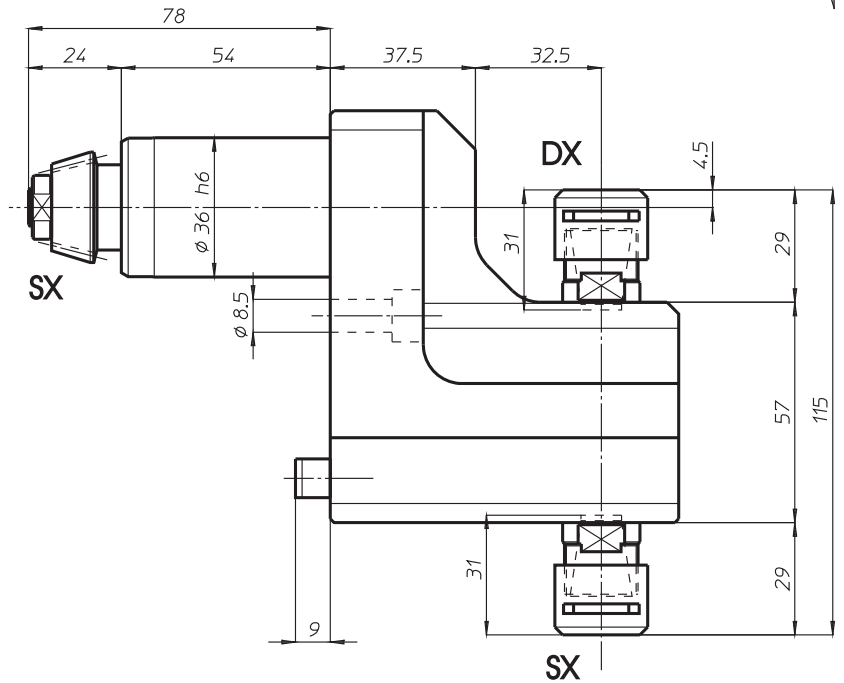
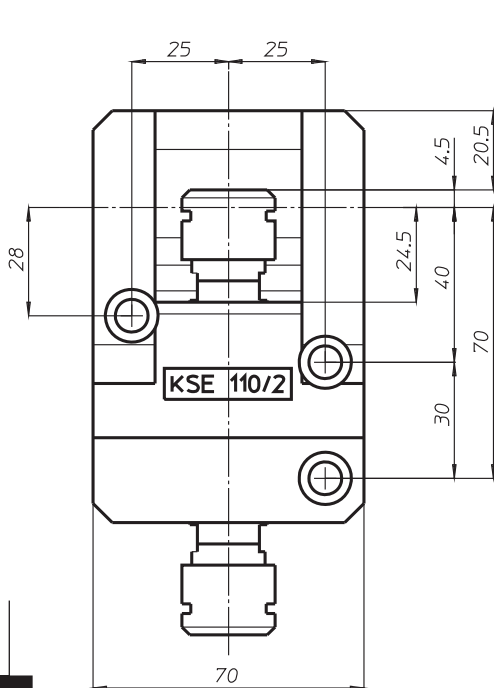

Caratteristiche - Features



$\phi 10$



M8

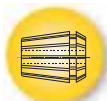

ER16



3.4



8000
RPM



SX



SX-DX

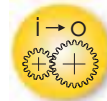

1-2



* NO



.



.



.

Macchina : CINCOM M20-M32

Torretta :

* Solo esterno *Outside only*

