

PORTAUTENSILI PER TORNI CNC CNC LATHE TOOLHOLDERS

TORNI CMZ CMZ LATHES

PORTAUTENSILI ASSIALI - AXIAL TOOLHOLDERS

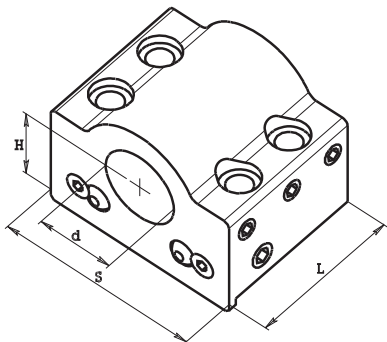

Con passaggio liquido refrigerante esterno o interno
With inner or outer coolant feeding system

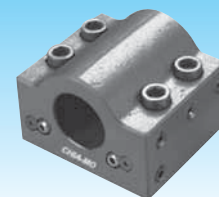

Code	CMZ code					
ART.	Cod. CMZ	d	H	S	L	Fig.
7C3.C40	TL15/10000/09	40	40	90	80	1
7C6.C40	TL20/10000/09	40	40	105	90	2
7C6.C40 R	TL20/10000/12	40	40	105	90	2
7C6.C50	TL20/10000/40	50	40	105	90	2

PORTAUTENSILI ASSIALI - AXIAL TOOLHOLDERS

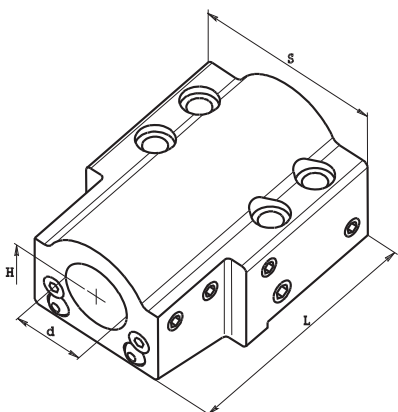

Con passaggio liquido refrigerante esterno o interno
With inner or outer coolant feeding system



Code	CMZ code					
ART.	Cod. CMZ	d	H	S	L	Fig.
7C3.L40	TL15/10000/10	40	40	90	135	1
7C6.L40	TL20/10000/10	40	40	105	160	2
7C6.L50	TL20/10000/39	50	40	105	160	2

PORTAUTENSILI ASSIALI - AXIAL TOOLHOLDERS

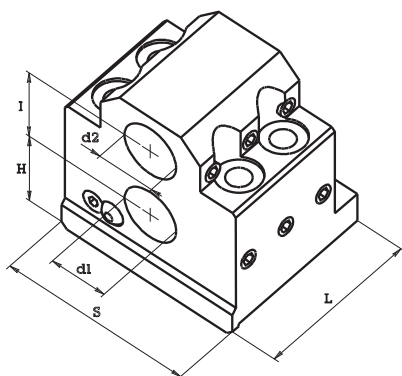

Con passaggio liquido refrigerante esterno o interno
With inner or outer coolant feeding system



Code	Doosan code						
ART.	Cod. Doosan	d1-d2	H	I	S	L	Fig.
7C3.D25	TL15/10000/11	25	40	35	90	75	1
7C6.D32	TL20/10000/11	32	40	45	105	90	2

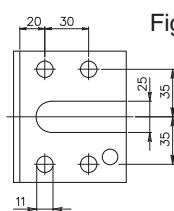
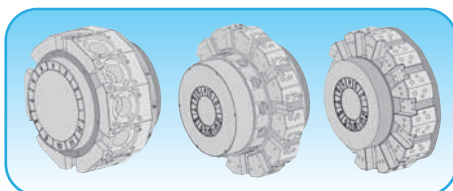

Fig. 1

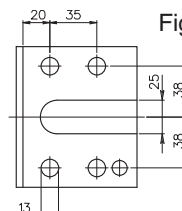

Fig. 2

**INTERASSE FORI
IN PORTAUTENSILI
DISTANCE BETWEEN HOLES
IN TOOLHOLDERS**



PORTAUTENSILI PER TORNI CNC
CNC LATHE TOOLHOLDERS

TORNI CMZ
CMZ LATHES

PORTAUTENSILI ASSIALI - AXIAL TOOLHOLDERS

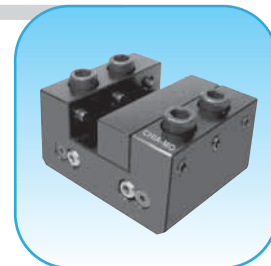
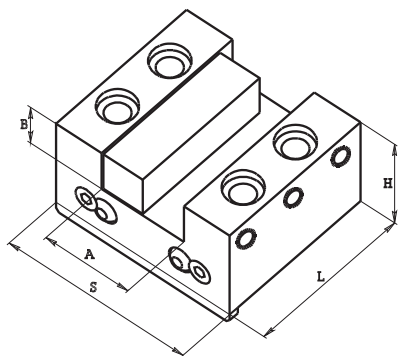

Code	CMZ code						
ART.	Cod. CMZ	A	B	S	L	H	Fig.
8C3.C40	TL15/10000/08	40	20	90	75	50	1
8C6.C50	TL20/10000/08	50	25	106	90	55	2

PORTAUTENSILI RADIALI - RADIAL TOOLHOLDERS

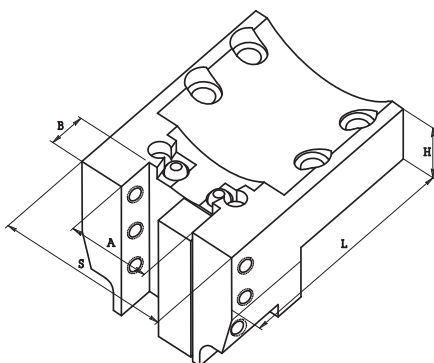

Code	CMZ code						
ART.	Cod. CMZ	A	B	S	L	H	Fig.
8C3.V40	TL15/10000/45	40	20	90	155	44	1
8C6.V50 L	TL20/10000/45	50	25	102	165	44	2

PORTAUTENSILI RADIALI - RADIAL TOOLHOLDERS

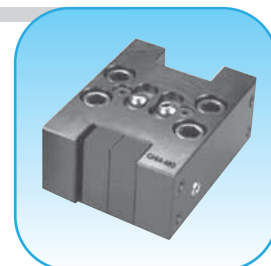
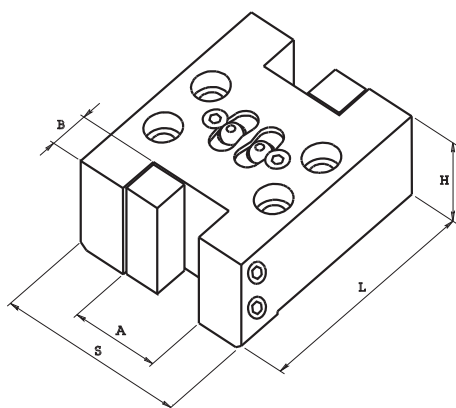

Code	CMZ code						
ART.	Cod. CMZ	A	B	S	L	H	Fig.
8C3.D40	TL15/10000/07	40	20	90	120	50	1
8C6.D50	TL20/10000/07	50	25	106	141	60	2

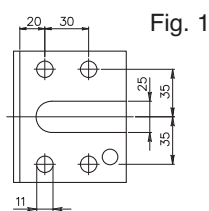
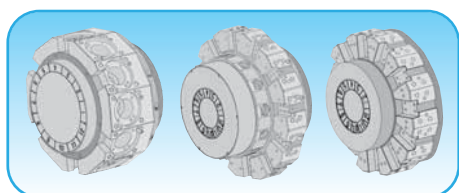

Fig. 1

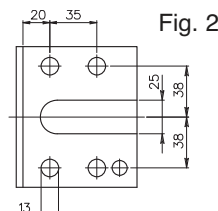

Fig. 2

INTERASSE FORI
IN PORTAUTENSILI
DISTANCE BETWEEN HOLES
IN TOOLHOLDERS



PORTAUTENSILI PER TORNI CNC CNC LATHE TOOLHOLDERS

TORNI CMZ CMZ LATHES

PORTAUTENSILI RADIALI - RADIAL TOOLHOLDERS

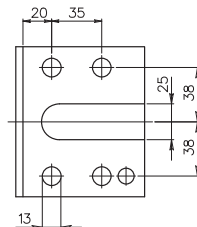
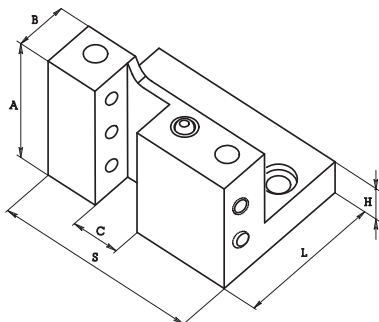

Code	CMZ code							Cut
ART.	Cod. CMZ	A	B	C	S	L	H	Taglio
8C6.B25	-	78	31	25	106	85	21	Dx

PORTAUTENSILI ASSIALI - AXIAL TOOLHOLDERS

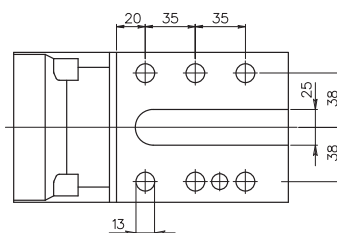
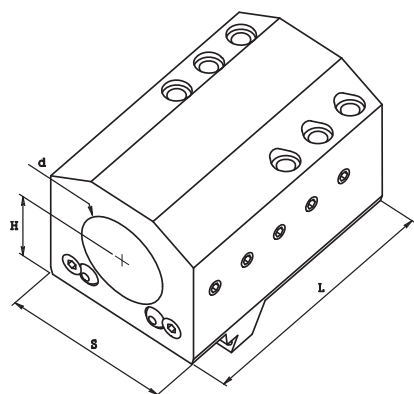

Code	CMZ code				
ART.	Cod. CMZ	d	H	S	L
7C8.L60	TC35/10000/54	60	50	106	180

PORTAUTENSILI ASSIALI - AXIAL TOOLHOLDERS

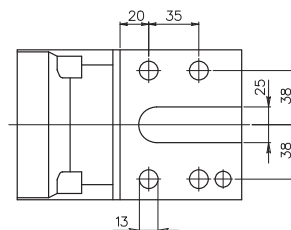
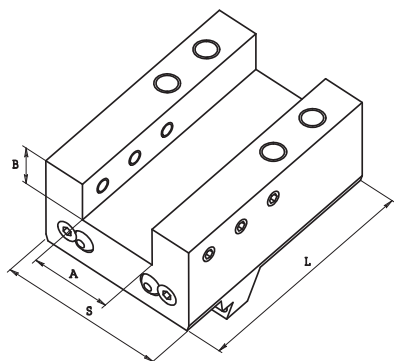

Code	CMZ code				
ART.	Cod. CMZ	A	B	S	L
8C8.L50	TC35/10000/57	50	25	106	165

