

DRIVEN TOOLING

For

**NEXTURN**

## NST 56

### DRIVEN

#### RADIAL DRIVEN TOOL

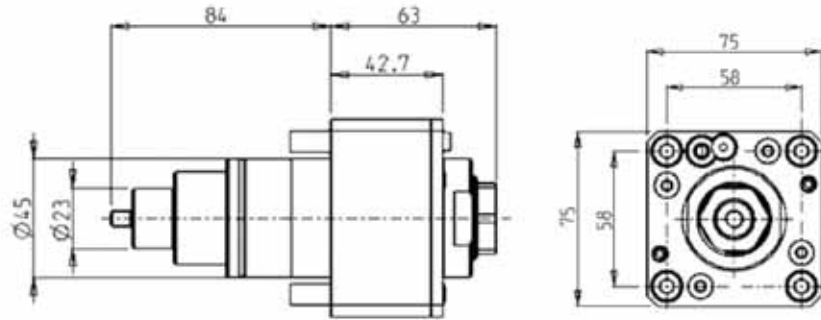

Part Number	Description	Spindle	I	RPM	Ext Coolant
DWO 0960125	Radial Driven Tool ER25	ERA25	1:1	6000	X

\* Coolant Thru tools are designed for 1000 psi.  
They require 5 Micron Filtration and **CANNOT** be run dry.

#### AXIAL REAR-SET DRIVEN TOOL

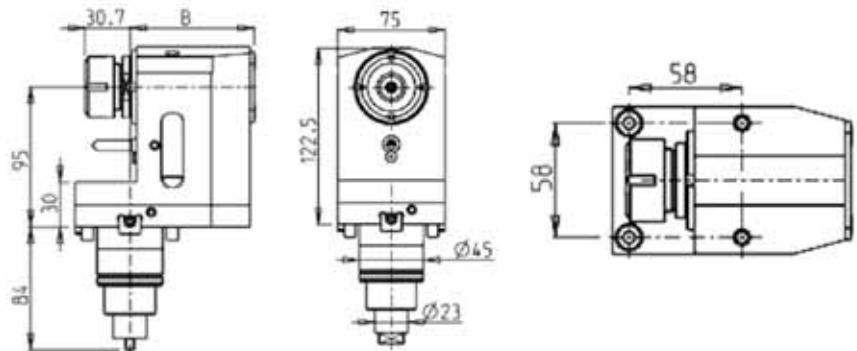

Part Number	Description	Spindle	I	RPM	Coolant Thru	Ext Coolant	B
DWO 0970125	Axial Rear-Set ER25	ER25	1:1	6000		X	85
DWO 0970225	Axial Rear-Set ER25 Coolant Thru*	ER25	1:1	6000	X	X	95

\* Coolant Thru tools are designed for 1000 psi.  
They require 5 Micron Filtration and **CANNOT** be run dry.

## NST 56

### DRIVEN

#### 0-180 ADJUSTABLE ANGLE DRIVEN TOOL

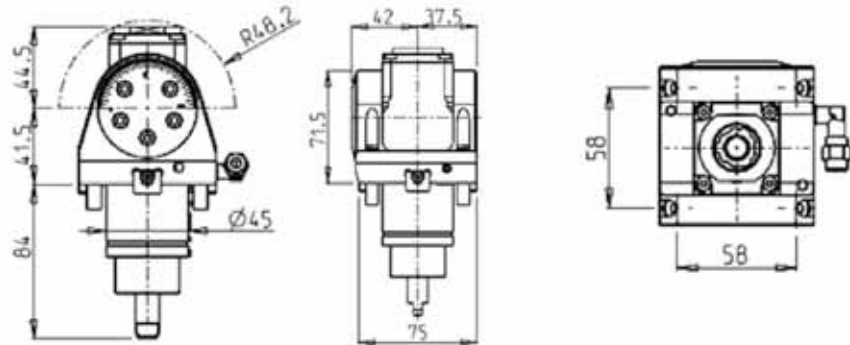

Part Number	Description	Reversible	Spindle	I	RPM	Ext. Coolant
DWO 0040116	0-180 Adjustable Angle ER16A Driven Tool	X	ERA 16	1:1	6000	X

**Note :**

Wrenches are provided with the purchase of Specialty Toolholders

## SA20/26/32/38

DRIVEN

### AXIAL DRIVEN TOOL

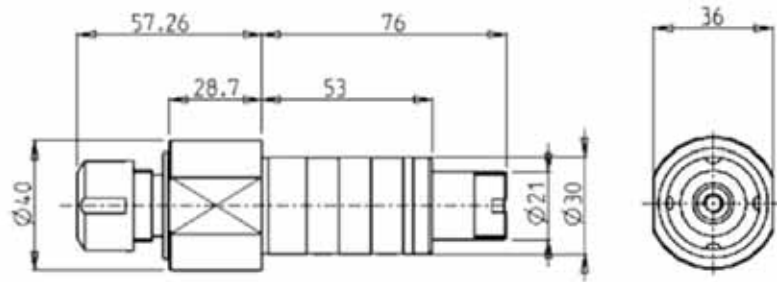

Part Number	Description	Spindle	Reversible	I	Ext. Coolant
NXT0010116	Axial Driven Tool ER16	ER16	X	1:1	X