

serie
VH

teste multiple ad assi variabili
variable axis heads

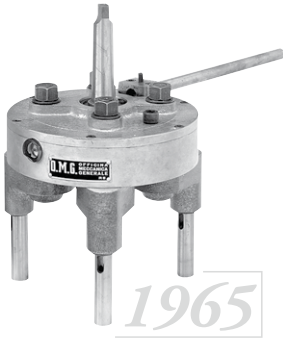

Lo sviluppo della serie TE, una linea completa di teste ad assi variabili, rappresenta l'innovazione degli anni '70 che sancisce a pieni voti il successo e la notorietà del marchio O.M.G.

Gli anni '80 sono dedicati al perfezionamento della linea TE e all'introduzione di due nuove serie; la TEM e la TEF. Il risultato é la messa a punto della più completa gamma di teste ad assi variabili presenti sul mercato nazionale ed internazionale.

Le tecnologie d'avanguardia nei processi produttivi e l'impiego di nuove tecniche computerizzate firmano la notorietà e l'immagine del marchio O.M.G.: un nome diffuso e conosciuto da tutte le aziende, piccole e grandi, un'immagine mai smentita ma sottolineata nelle numerose campagne pubblicitarie realizzate.

L'ultima generazione, la serie VH, racchiude gli elementi di tecnologia e know how delle teste multiple ad interassi fissi. Si tratta di strumenti ad alta prestazione che consentono agli utilizzatori l'impiego ottimale di tutte le più avanzate tecnologie applicate agli utensili.

La VH rappresenta una serie completamente diversa, sia sotto il profilo tecnologico che estetico: un prodotto per il quale anche la ricerca ergonomica é stata assolutamente meticolosa.



The TE series, a complete range of variable axes heads, represented a major company achievement in the seventies: it was a success and brought OMG into the limelight.

The eighties were characterised by upgrades to the TE range and the addition of two new series TEM and TEF.

Together this forms the most complete range of variable axis heads on domestic and international markets.

Cutting-edge technologies in production processes and the use of new computerised methods are the hallmarks of the O.M.G. brand name and image

thanks to which the company has won renown among small and large enterprises alike, an image that has never lost its importance but which is, instead, stressed by frequent advertising campaigns.



The latest generation, the VH series, bears witness to the technology and "know how" of multispindle heads with fixed centres and allows the end user to fully exploit the latest developments in tool manufacturing.

This new VH series, so different in terms of technology and aesthetics, is also the result of meticulous ergonomic research.



VH 04.....	6-2
VH 06.....	6-4
VH 08.....	6-6
VH 10.....	6-8
VH 13.....	6-10
VH 18.....	6-12
VH 25.....	6-14
VH 101.....	6-16
VH 181.....	6-17
Regolazione utensili/Tool settings	6-18
Esecuzioni speciali/Special executions	6-19
Galleria fotografica/Photographic gallery.....	6-20
Accessori/Accessories	10-1

Dimensione mandrini/Spindle dimensions ...	11-3
--	------

BAH

TA.CP

TA

MO

HT

VH

TSI/TSX

T

MT-TC-TC3

Accessori
Accessories

Appendice tecnica
Technical supplement

6-1



CAPACITA' FORATURA
DRILLING CAPACITY $\phi 5$

VH

modello 04

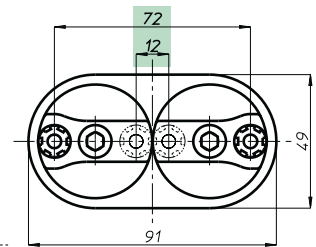
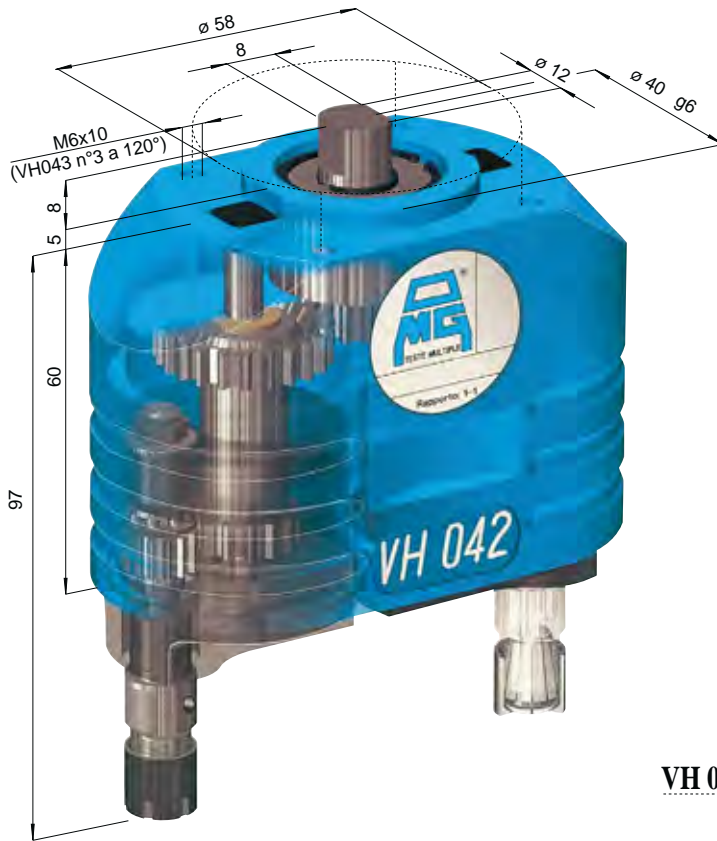

VH 042

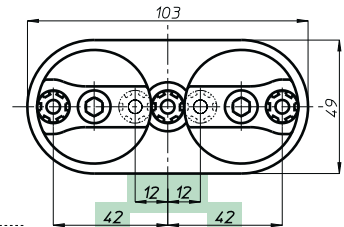

VH 043 L

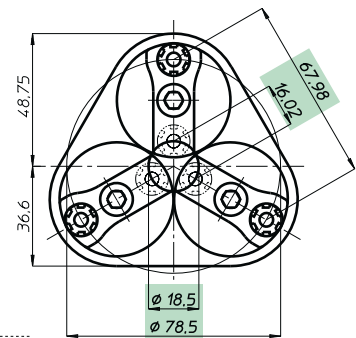

VH 043

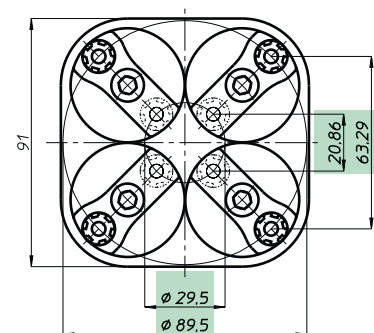

VH 044

Testa modello Head type	VH 042	VH 043 L	VH 043	VH 044
Articolo Item	VH 042 PV	VH 043 LP	VH 043 P	VH 044 P
Attacco utensile Spindle type	ER 8 - max $\phi 5$			
Articolo Item				
Attacco utensile Spindle type				
N. mandrini Spindles nr.	2	3	3	4
Campo di lavoro min.	12	12 + 12	$\phi 18,5$	$\phi 29,5$
Centre distances max.	72	42 + 42	$\phi 78,5$	$\phi 89,5$
Capacità foratura Drilling capacity	Acciaio Rm 500 N/mm ² - $\phi 4$			
Maschiatura Tapping	Ghisa GG25 - $\phi 5$			
Rapporto Ratio	M 3			
Velocità RPM	1 - 1			
Peso Weight	0,95	1,05	1,4	1,9

Teste multiple ad assi variabili - Variable axis heads

BAH

TA-CP

TA

MO

HT

VH

TSI/TSX

T

MT-TC-TC3

Accessori
Accessories

Appendice tecnica
Technical supplement

6-2



NOTA: A.B.C.D. dati macchina
 NOTE: A.B.C.D. machine features

DIN 238	CODICE
B 10	011277
B 12	011278
B 16	011279
B 18	011280

DIN 55058	CODICE
16	525405
20	525406
28	525407

DIN 228	CODICE
CM 1	011115
CM 2	011120
CM 3	011125

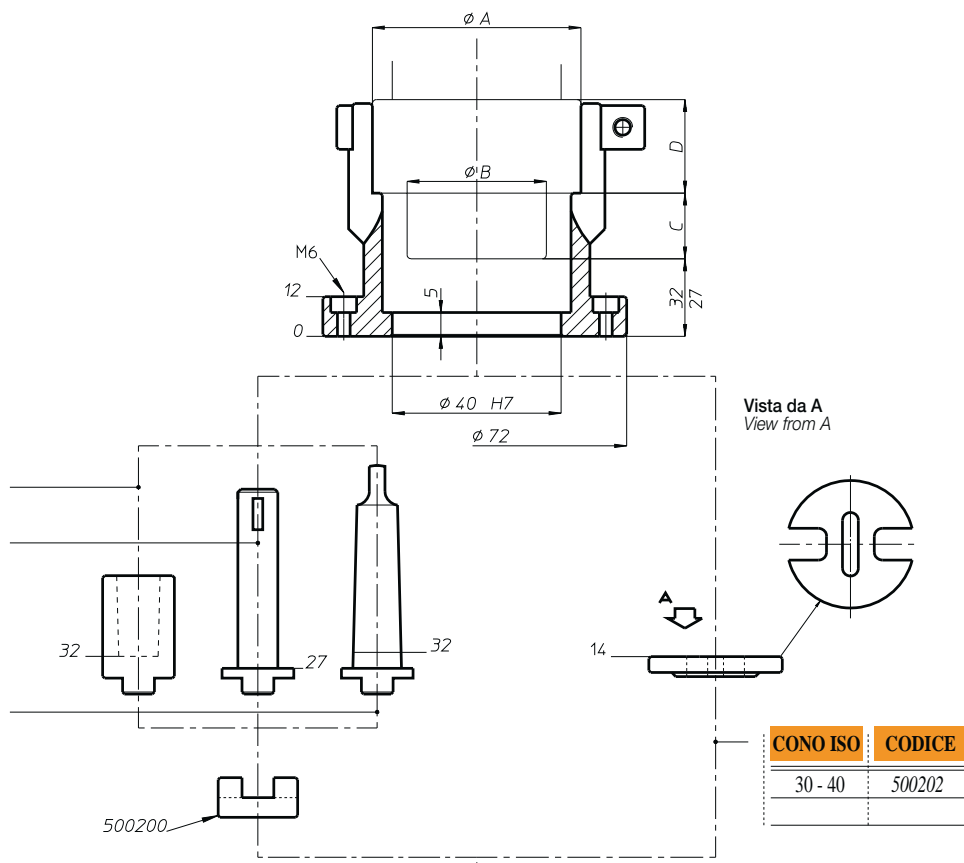

Teste multiple ad assi variabili • Variable axis heads

CAPACITA' FORATURA
DRILLING CAPACITY $\phi 7$

VH

modello 06

Teste multiple ad assi variabili - Variable axis heads

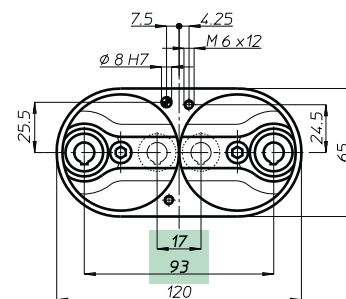
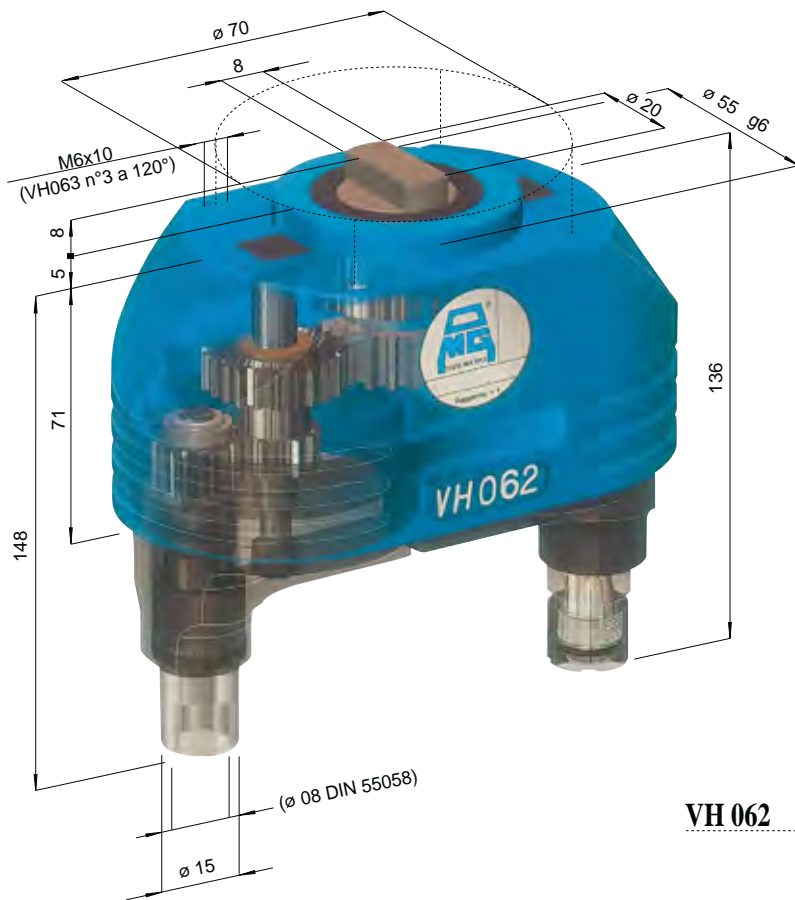

VH 062

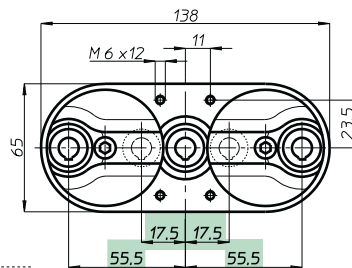

VH 063 L

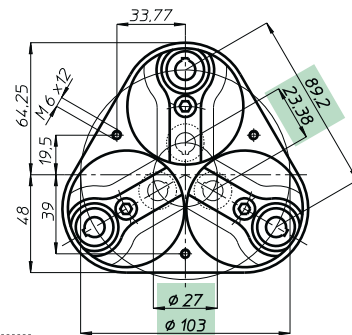

VH 063

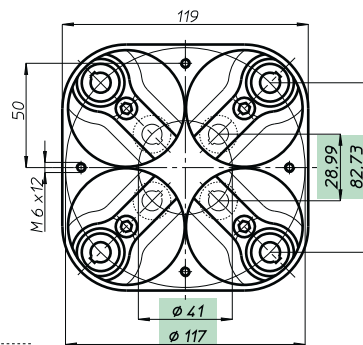

VH 064

Testa modello Head type	VH 062	VH 063 L	VH 063	VH 064
Articolo Item	VH 062 P	VH 063 LP	VH 063 P	VH 064 P
Attacco utensile Spindle type	ER 11 - max $\phi 7$			
Articolo Item	VH 062 D	VH 063 LD	VH 063 D	VH 064 D
Attacco utensile Spindle type	DIN 55058 - $\phi 8$			
N. mandrini Spindles nr.	2	3	3	4
Campo di lavoro min.	17	17,5 + 17,5	$\phi 27$	$\phi 41$
Centre distances max.	93	55,5 + 55,5	$\phi 103$	$\phi 117$
Capacità foratura Drilling capacity	Acciaio Rm 500 N/mm ² - $\phi 6$			
Maschiatura Tapping	Ghisa GG25 - $\phi 7$			
Rapporto Ratio	M 5			
Velocità RPM	1 - 1			
Peso Weight	1,65	1,95	2,3	3,1

BAH

TA-CP

TA

MO

HT

VH

TSI/TSX

T

MT-TC-TC3

Accessori
Accessories

Appendice tecnica
Technical supplement

6-4



MANICOTTO DI COLLEGAMENTO - CONNECTION COLLAR

NOTA: A.B.C.D. dati macchina
NOTE: A.B.C.D. machine features

DIN 238	CODICE
B 10	011277
B 12	011278
B 16	011279
B 18	011280
B 22	011281
B 24	011282

DIN 55058	CODICE
16	525405
20	525406
28	525407
36	525408

DIN 228	CODICE
CM 1	011115
CM 2	011120
CM 3	011125
CM 4	011130
CM 5	011135

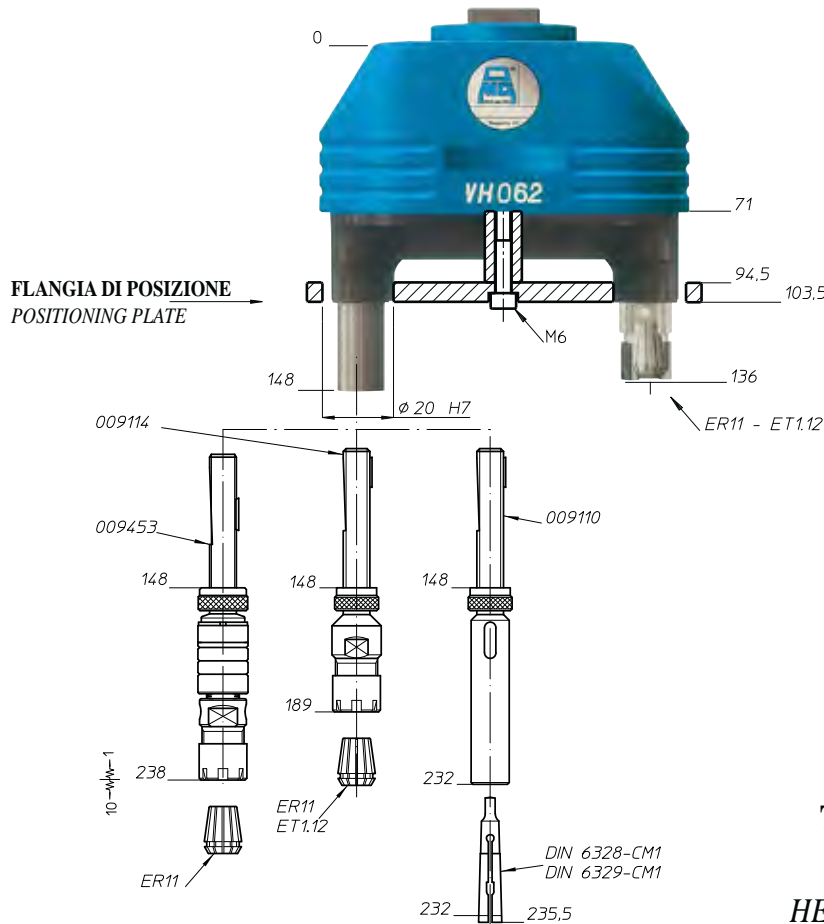
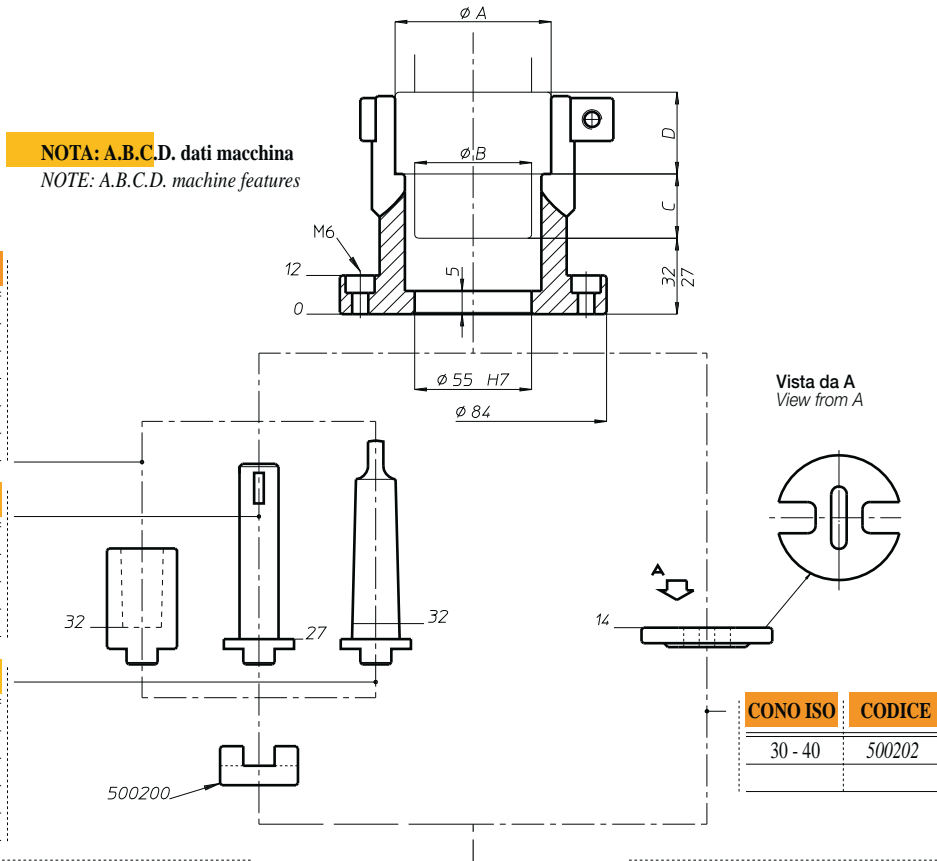

**ACCESSORI PER
TESTE MULTIPLE
MULTISPINDLE
HEADS ACCESSORIES**

Teste multiple ad assi variabili - Variable axis heads

CAPACITA' FORATURA
DRILLING CAPACITY ϕ 10

VH

modello 08

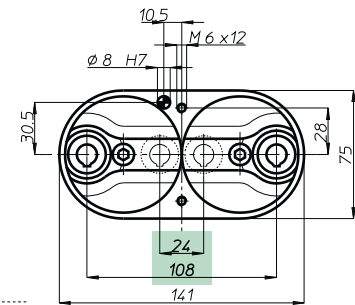
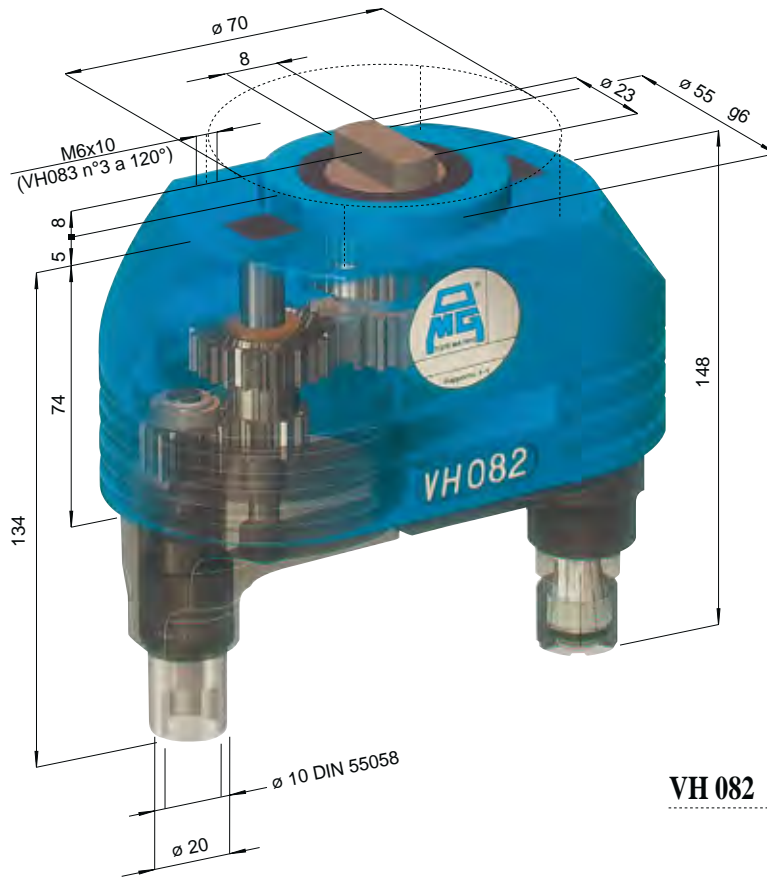

VH 082

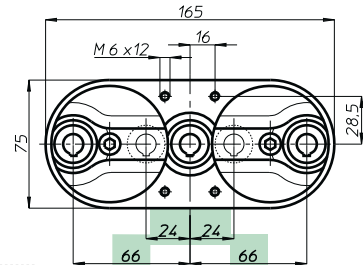

VH 083 L

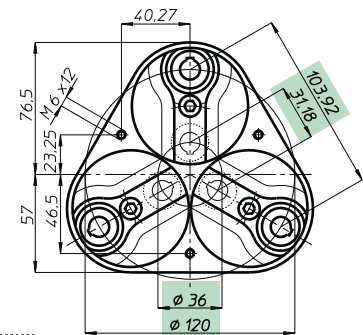

VH 083

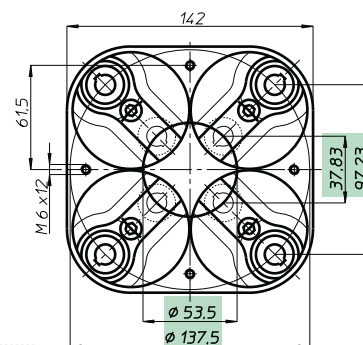

VH 084

Testa modello Head type	VH 082	VH 083 L	VH 083	VH 084
Articolo Item	VH 082 P	VH 083 LP	VH 083 P	VH 084 P
Attacco utensile Spindle type	ER 16 - max ϕ 10			
Articolo Item	VH 082 D	VH 083 LD	VH 083 D	VH 084 D
Attacco utensile Spindle type	DIN 55058 - ϕ 10			
N. mandrini Spindles nr.	2	3	3	4
Campo di lavoro min.	24	24 + 24	ϕ 36	ϕ 53,5
Centre distances max.	108	66 + 66	ϕ 120	ϕ 137,5
Capacità foratura	Acciaio Rm 500 N/mm ² - ϕ 8			
Drilling capacity	Ghisa GG25 - ϕ 10			
Maschiatura Tapping	M 6			
Rapporto Ratio	1 - 1			
Velocità RPM	4.000			
Peso Weight	Kg. 2,2	2,9	3,4	4,6

Teste multiple ad assi variabili • Variable axis heads

BAH

TA-CP

TA

MO

HT

VH

TSI/TSX

T

MT-TC-TC3

Accessori
Accessories

Appendice tecnica
Technical supplement

6-6



MANICOTTO DI COLLEGAMENTO - CONNECTION COLLAR

NOTA: A.B.C.D. dati macchina
NOTE: A.B.C.D. machine features

DIN 238	CODICE
B 10	011277
B 12	011278
B 16	011279
B 18	011280
B 22	011281
B 24	011282

DIN 55058	CODICE
16	525405
20	525406
28	525407
36	525408

DIN 228	CODICE
CM 1	011115
CM 2	011120
CM 3	011125
CM 4	011130
CM 5	011135

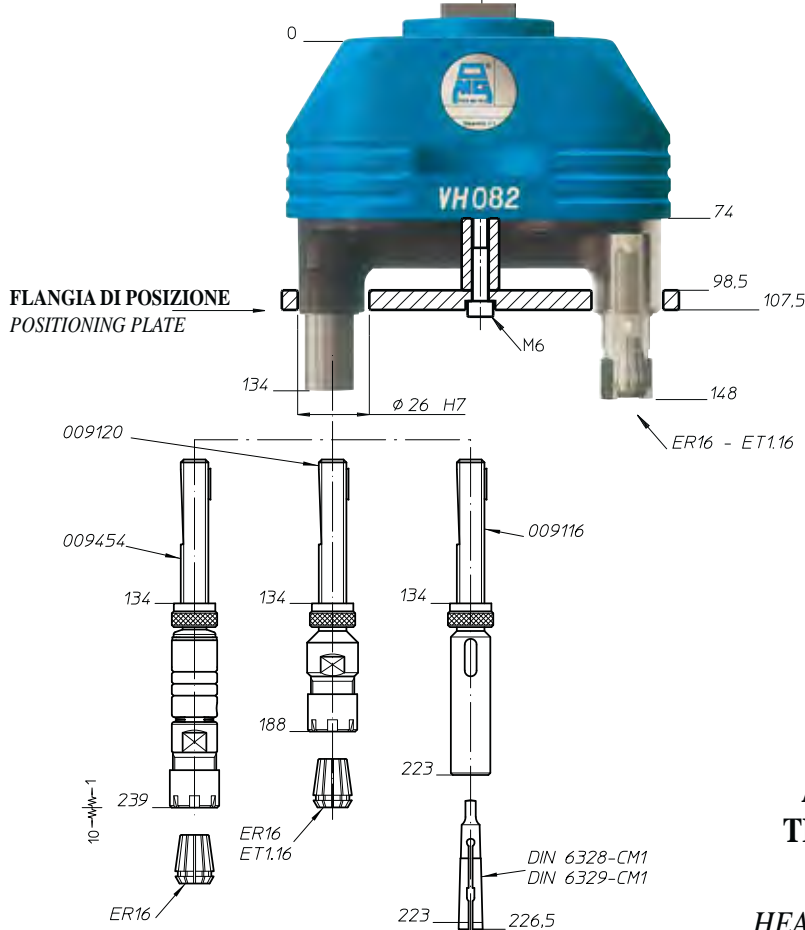
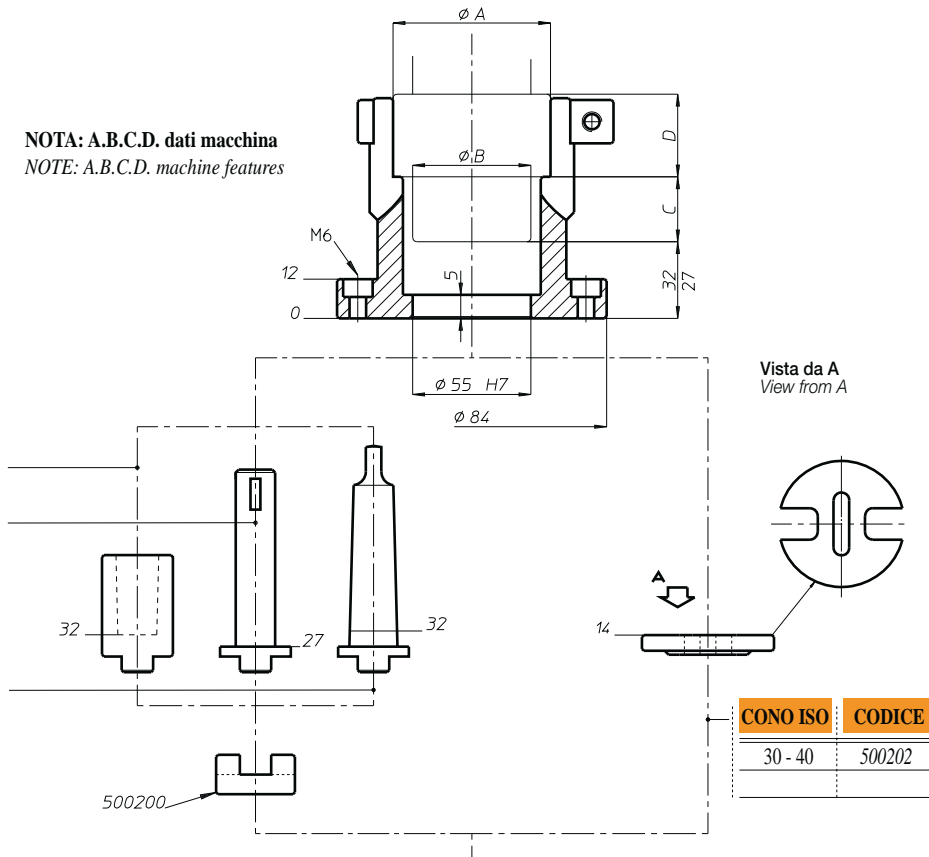

**ACCESSORI PER
TESTE MULTIPLE**
**MULTISPINDLE
HEADS ACCESSORIES**

Teste multiple ad assi variabili • Variable axis heads



CAPACITA' FORATURA
DRILLING CAPACITY $\phi 12$

VH

modello 10

Teste multiple ad assi variabili • Variable axis heads

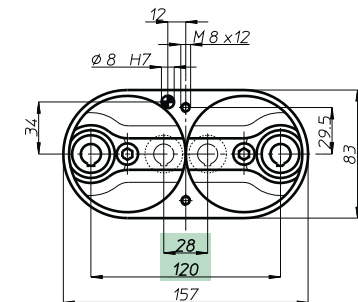
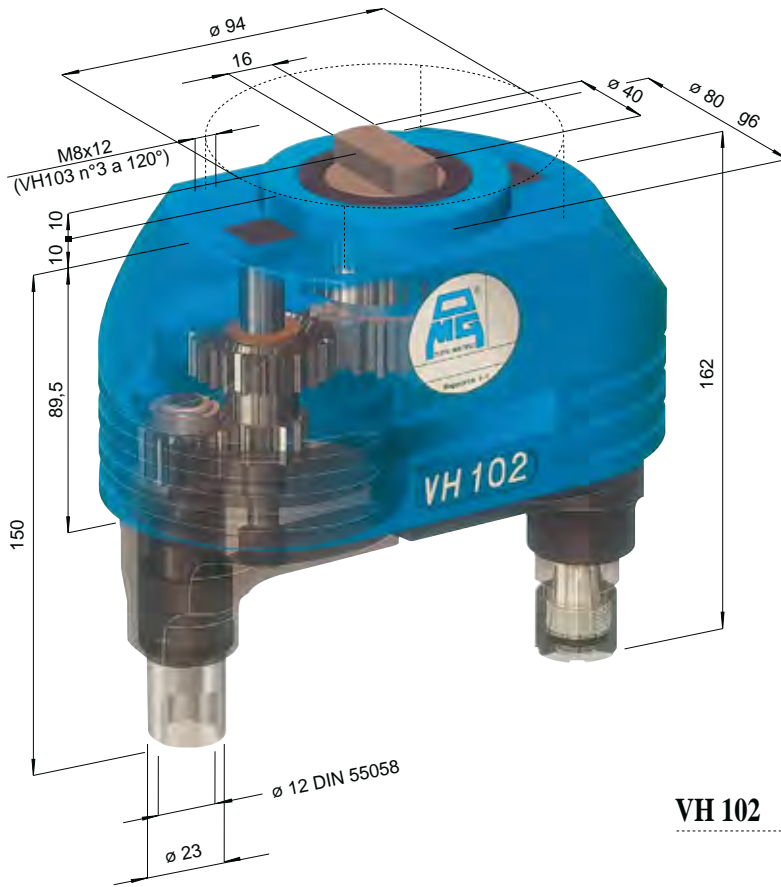

VH 102

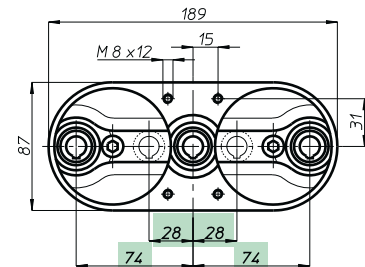

VH 103 L

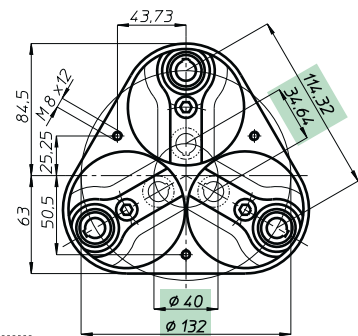

VH 103

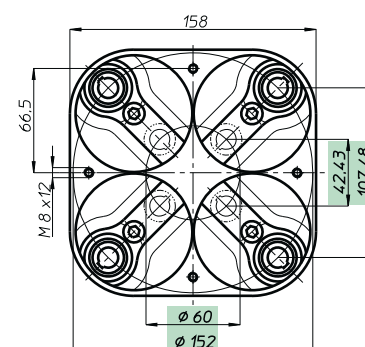

VH 104

Testa modello Head type	VH 102	VH 103 L	VH 103	VH 104	
Articolo Item	VH 102 P	VH 103 LP	VH 103 P	VH 104 P	
Attacco utensile Spindle type	ER 16 - max $\phi 10$				
Articolo Item	VH 102 D	VH 103 LD	VH 103 D	VH 104 D	
Attacco utensile Spindle type	DIN 55058 - $\phi 12$				
N. mandrini Spindles nr.	2	3	3	4	
Campo di lavoro min.	28	28 + 28	$\phi 40$	$\phi 60$	
Centre distances max.	120	74 + 74	$\phi 132$	$\phi 152$	
Capacità foratura Drilling capacity	Acciaio Rm 500 N/mm ² - $\phi 10$				
Maschiatura Tapping	Ghisa GG25 - $\phi 12$				
Rapporto Ratio	M 8				
Velocità RPM	1 - 1				
Peso Weight	3.500				
	Kg.	3,5	4,9	4,9	7,2



MANICOTTO DI COLLEGAMENTO - CONNECTION COLLAR

NOTA: A.B.C.D. dati macchina
NOTE: A.B.C.D. machine features

DIN 238	CODICE
B 10	011277
B 12	011278
B 16	011279
B 18	011280
B 22	011281
B 24	011282

DIN 55058	CODICE
16	525405
20	525406
28	525407
36	525408

DIN 228	CODICE
CM 1	011115
CM 2	011120
CM 3	011125
CM 4	011130
CM 5	011135

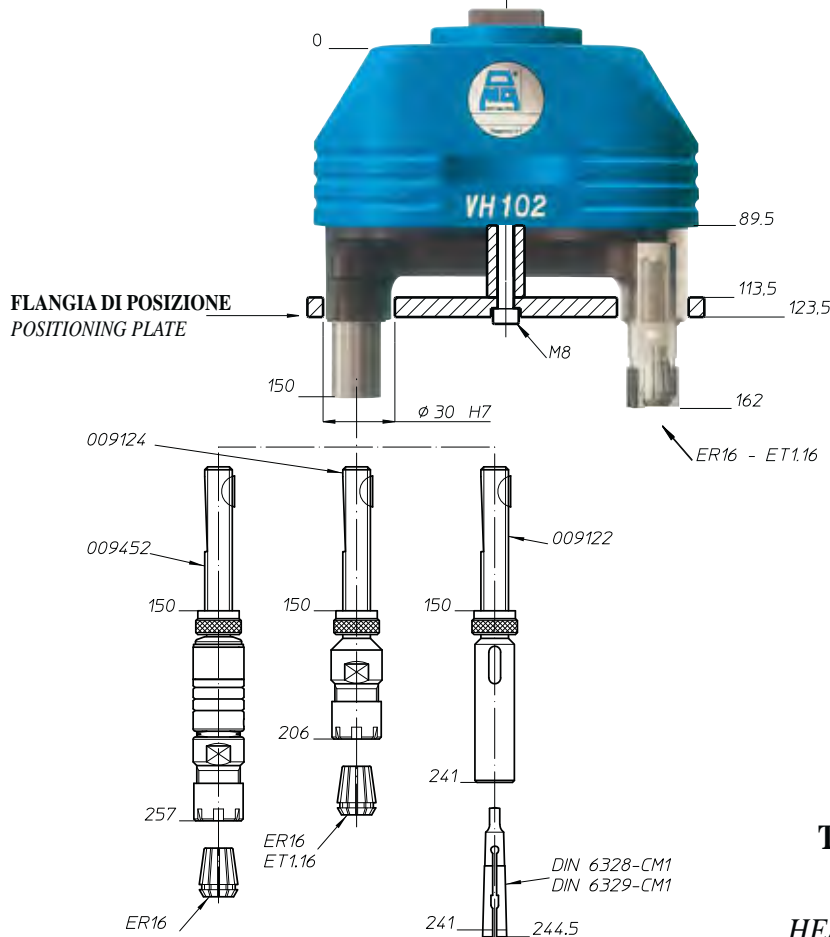
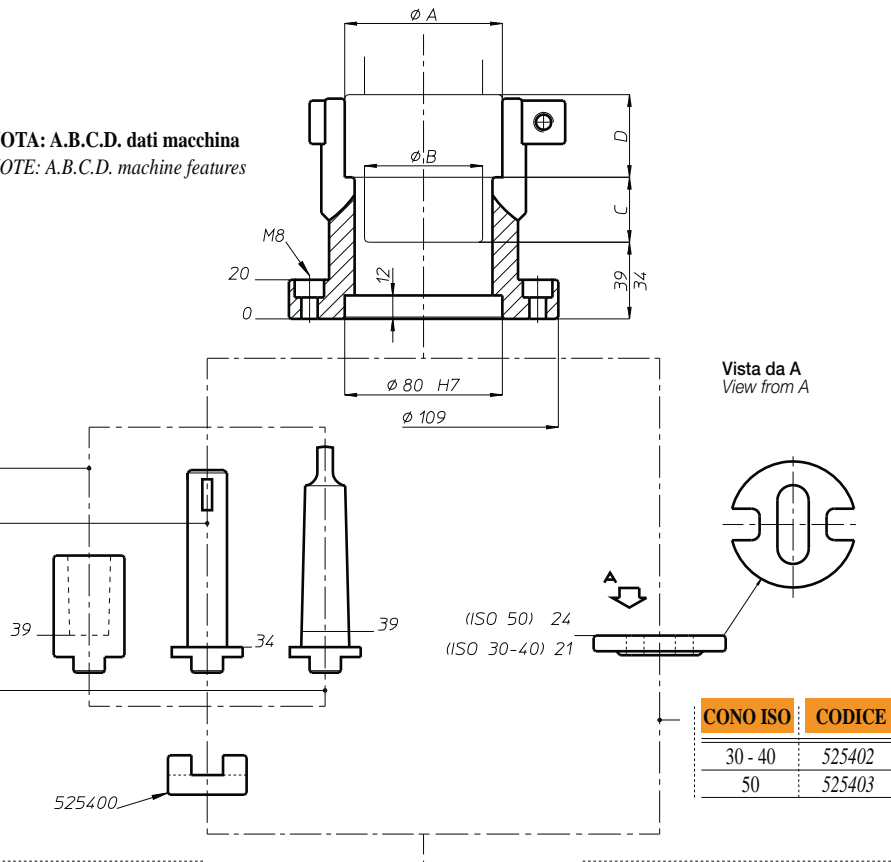

**ACCESSORI PER
TESTE MULTIPLE**
**MULTISPINDLE
HEADS ACCESSORIES**

Teste multiple ad assi variabili • Variable axis heads



NOTA: A.B.C.D. dati macchina
NOTE: A.B.C.D. machine features

DIN 238	CODICE
B 16	011279
B 18	011280
B 22	011281
B 24	011282

DIN 55058	CODICE
16	525405
20	525406
28	525407
36	525408

DIN 228	CODICE
CM 3	011125
CM 4	011130
CM 5	011135

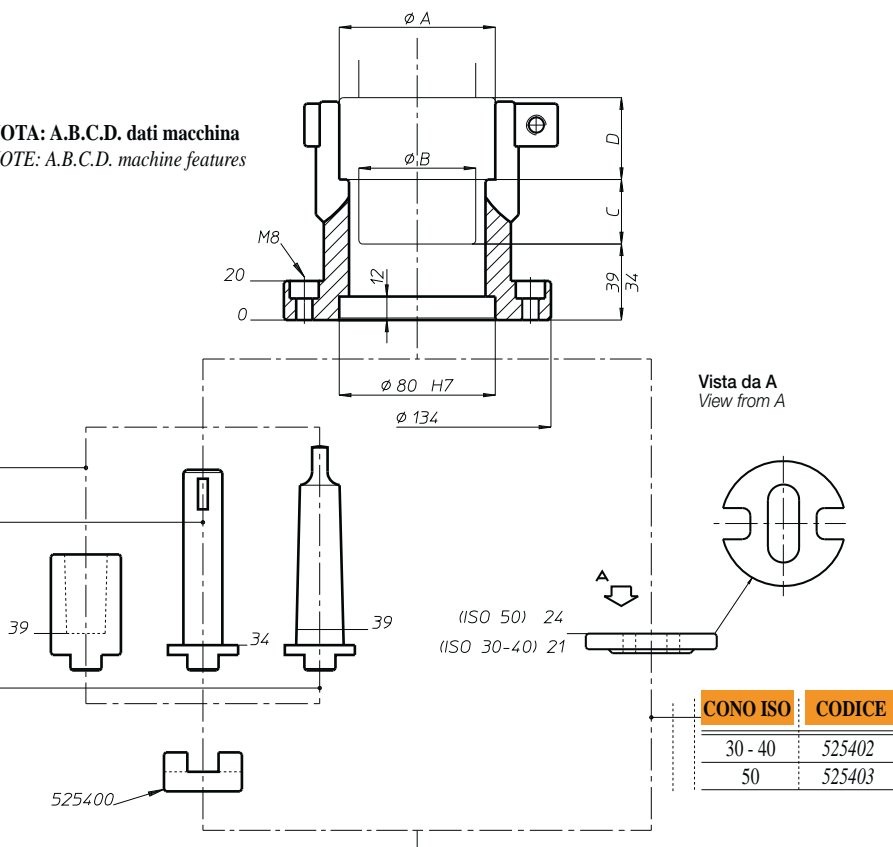

NOTA:

la lunghezza degli accessori, comprensivi di manicotto attacco rapido, aumenta di mm 10.

NOTE:
the length of this accessories whit quick connection sleeve increases of mm 10.

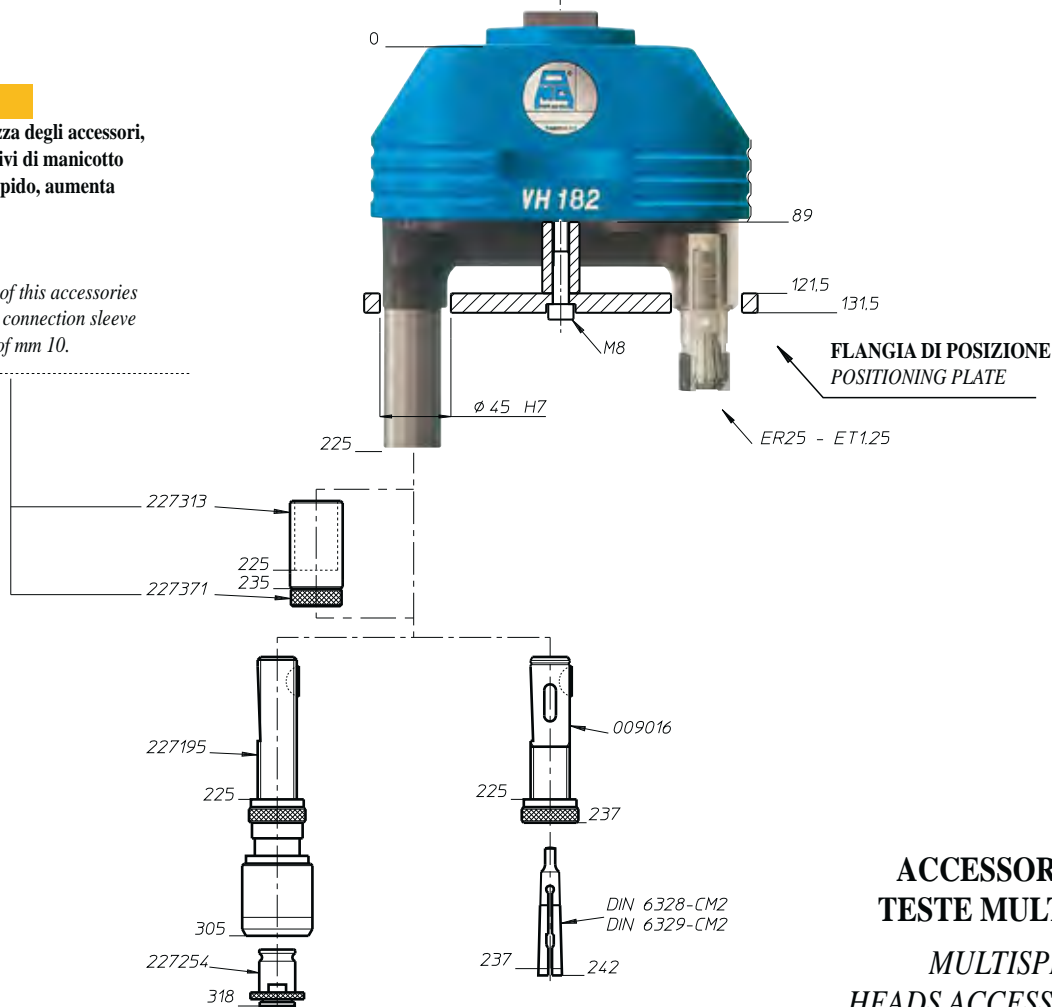

**ACCESSORI PER
TESTE MULTIPLE
MULTISPINDLE
HEADS ACCESSORIES**

Teste multiple ad assi variabili - Variable axis heads

NOTA: A.B.C.D. dati macchina
NOTE: A.B.C.D. machine features

DIN 238	CODICE
B 18	011280
B 22	011281
B 24	011282

DIN 55058	CODICE
16	525405
20	525406
28	525407
36	525408

DIN 228	CODICE
CM 3	011125
CM 4	011130
CM 5	011135

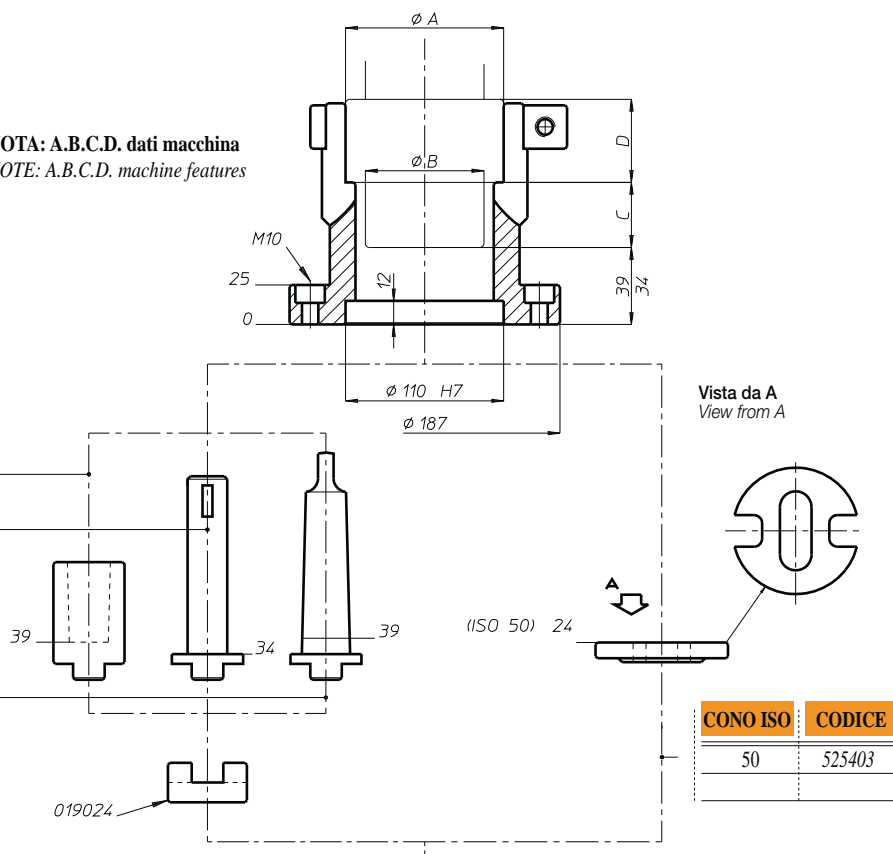

NOTA:

la lunghezza degli accessori, comprensivi di manicotto attacco rapido, aumenta di mm 12.

NOTE:

the length of this accessories whit quick connection sleeve increases of mm 12.

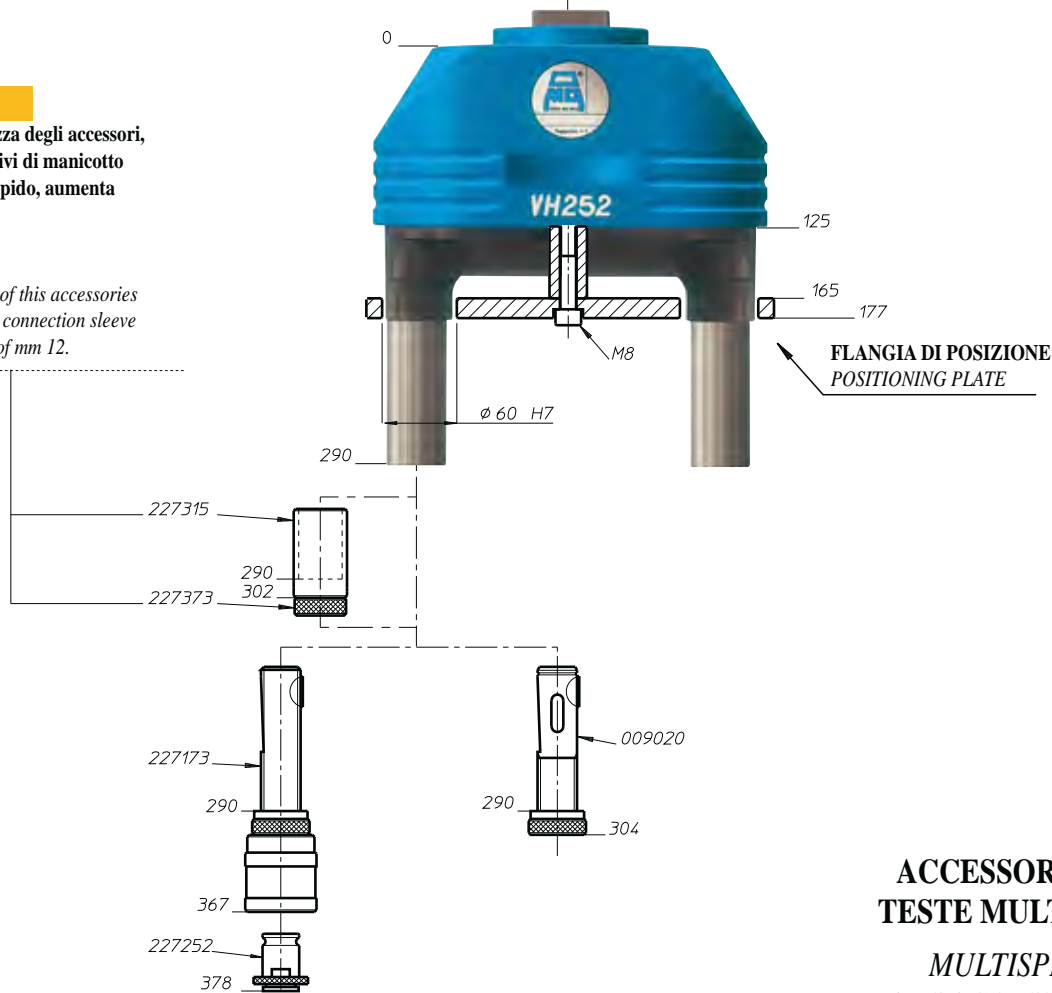

**ACCESSORI PER
TESTE MULTIPLE
MULTISPINDLE
HEADS ACCESSORIES**

Teste multiple ad assi variabili - Variable axis heads

CAPACITA' FORATURA
DRILLING CAPACITY ϕ 12

VH

modello 101

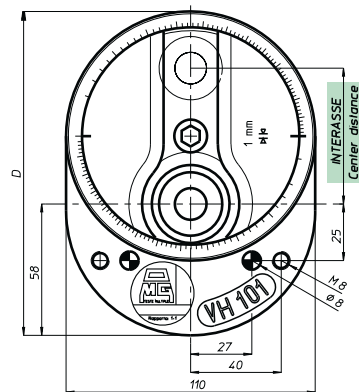

VISTA
VIEW H

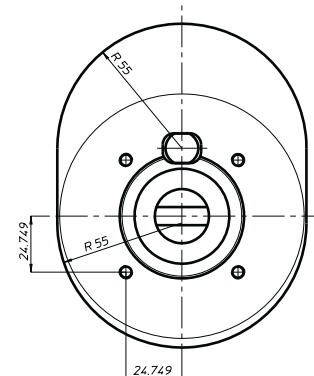

VISTA
VIEW L

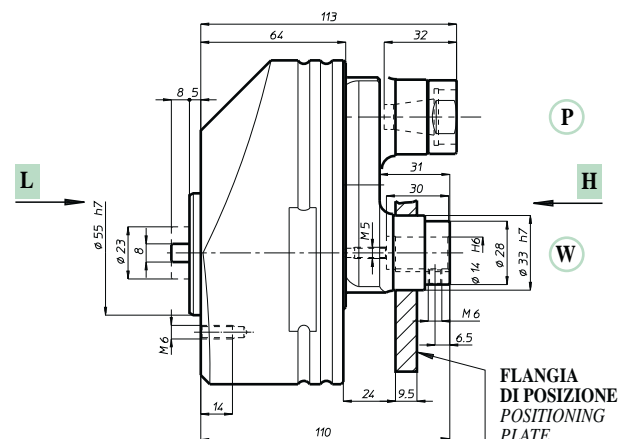

FLANGIA
DI POSIZIONE
POSITIONING
PLATE

Testa modello Head type	VH 101	
Articolo Item	VH 101 P	
Attacco utensile Spindle type	ER16 - max ϕ 10	
Articolo Item	VH 101 W14	
Attacco utensile Spindle type	ϕ 14	
N. mandrini Spindles nr.	1	
Campo di lavoro min.	0	
Centre distances max.	60	
D	143	
Capacità foratura	Acciaio Rm 500 N/mm ² - ϕ 10	
Drilling capacity	Ghisa GG25 - ϕ 12	
Maschiatura Tapping	M 10	
Rapporto Ratio	1 - 1	
Velocità RPM	3.000	
Peso Weight	Kg. 2,8	

Teste multiple ad assi variabili • Variable axis heads

BAH

TA-CP

TA

MO

HT

VH

TSI/TSX

T

MT-TC-TC3

Accessori
Accessories

Appendice tecnica
Technical supplement



CAPACITA' FORATURA
DRILLING CAPACITY ϕ 20

VH

modello 181



Testa modello
Head type

**VH
181**

**VH
181-122**

Articolo
Item

VH 181 P

VH 181-122-P

Attacco utensile
Spindle type

ER25 - max ϕ 16

Articolo
Item

VH 181 W16

VH 181-122-W16

Attacco utensile
Spindle type

ϕ 16

N. mandrini
Spindles nr.

1

1

Campo
di lavoro min.

0

56

Centre
distances max.

66

122

D

166

222

Capacità
foratura

Acciaio Rm 500 N/mm² - ϕ 18

Drilling
capacity

Ghisa GG25 - ϕ 20

Maschiatura
Tapping

M 14

Rapporto
Ratio

1 - 1

Velocità
RPM

2.500

Peso
Weight

Kg.

4,1

6,4

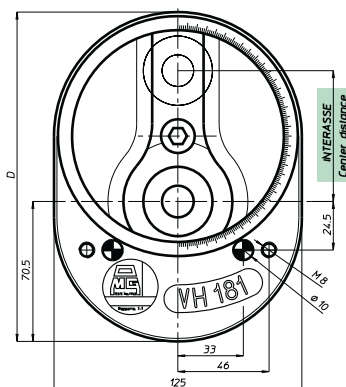

VISTA
VIEW H

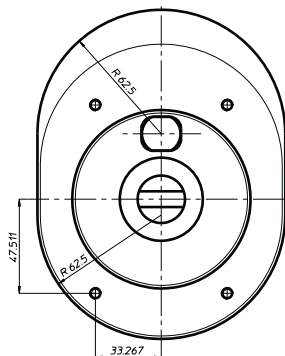

VISTA
VIEW L

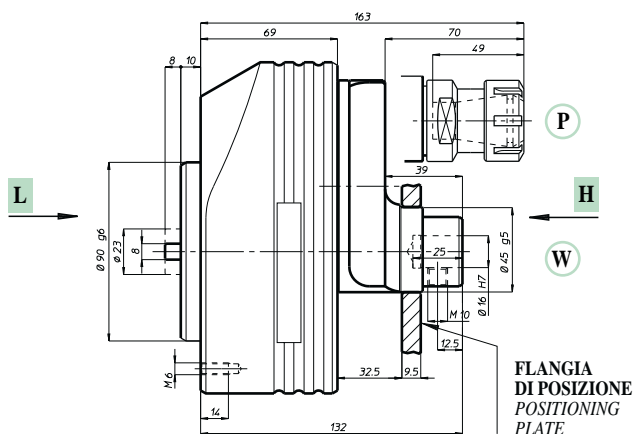

FLANGIA
DI POSIZIONE
POSITIONING
PLATE

Teste multiple ad assi variabili • Variable axis heads

BAH

TA.CP

TA

MO

HT

VH

TSI/TSX

T

MT-TC-TC3

Accessori
Accessories

Appendice tecnica
Technical supplement

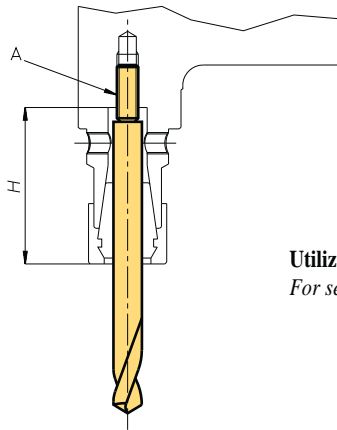
FORATURA CON PINZE ER
DRILLING WITH ER COLLETS

Testa Head	VH 04	VH 06	VH 08	VH 10	VH 13	VH 18
H max	23	27	44	44	52	49

NOTA: nella testa VH04 e VH06 la vite A non è presente
NOTE: in the head VH04 and VH06 there isn't the screw A

Utilizzare la vite A sinistra per registrare l'altezza utensile
For setting the tool length, use the left screw A

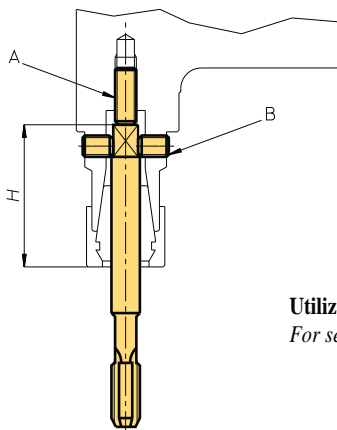
MASCHIATURA CON PINZE ER
TAPPING WITH ER COLLETS

Testa Head	VH 04	VH 06	VH 08	VH 10	VH 13	VH 18
H max	23	27	38	38	44	49

NOTA: nella testa VH04 e VH06 la vite A non è presente
NOTE: in the head VH04 and VH06 there isn't the screw A

Utilizzare la vite A per registrare l'altezza utensile e le viti B per bloccare il quadro del maschio
For setting the tool length, use the screw A; locking the tap square with the screws B



Teste multiple ad assi variabili • Variable axis heads



VH 042 LP	n° 2 mandrini a pinza, min. 24 max. 84	<i>2 spindles for spring collets min. 24 max. 84</i>
VH 042P R. 1-2	n° 2 mandrini a pinza, min. 12 max. 72 rapp. 1-2	<i>2 spindles for spring collets min. 12 max. 72 ratio 1-2</i>
VH 062 LP	n° 2 mandrini a pinza, min. 35 max. 111	<i>2 spindles for spring collets min. 35 max. 111</i>
VH 062 LD	n° 2 mandrini DIN 55058-8 min. 35 max. 111	<i>2 spindles DIN 55058-8 min. 35 max. 111</i>
VH 062/1	n° 1 mandrino a pinza, min. 8,5 max. 46,5	<i>1 spindle for spring collets min. 8,5 max. 46,5</i>
VH 062P R.1-2	n° 2 mandrini a pinza min. 17 max. 93 rapp. 1-2, 067	<i>2 spindles for spring collets min. 17 max. 93 ratio 1-2,067</i>
VH 062P CNC40	n° 2 mandrini a pinza min. 17 max. 93 completa di cono ISO 40	<i>2 spindles for spring collets min. 17 max. 93 with shank ISO 40</i>
VH 063P CNC40	n° 3 mandrini a 120° a pinza min. 27 max. 103 completa di cono ISO 40	<i>3 spindles at 120° for spring collets min. 27 max. 103 with shank ISO 40</i>
VH 064P CNC40	n° 4 mandrini a 90° a pinza min. 41 max. 117 completa di cono ISO 40	<i>4 spindles at 90° for spring collets min. 41 max. 117 with shank ISO 40</i>
VH 064/3P	n° 3 mandrini a pinza min. 41 max. 117	<i>3 spindles for spring collets min. 41 max. 117</i>
VH 081 P	n° 1 mandrino a pinza min. 0 max. 42	<i>1 spindle for spring collets min. 0 max. 42</i>
VH 082 LP	n° 2 mandrini a pinza min. 48 max. 132	<i>2 spindles for spring collets min. 48 max. 132</i>
VH 082 LD	n° 2 mandrini DIN 55058 - 10 min. 48 max. 132	<i>2 spindles DIN 55058 - 10 min. 48 max. 132</i>
VH 082 P R. 1-2	n° 2 mandrini a pinza min. 24 max. 108 rapp. 1-2	<i>2 spindles for spring collets min. 24 max. 108 ratio 1-2</i>
VH 082P CNC 40	n° 2 mandrini a pinza min. 24 max. 108 completa di cono ISO 40	<i>2 spindles for spring collets min. 24 max. 108 with shank ISO 40</i>
VH 082PFM	n° 2 mandrini a pinza min. 24 max. 108 fora/maschia	<i>2 spindles for spring collets min. 24 max. 108 drilling and tapping</i>
VH 083 LP CNC40	n° 3 mandrini in linea a pinza min. 24+24 max. 66+66 completa di cono ISO 40	<i>3 spindles on line for spring collets min. 24+24 max. 66+66 with shank ISO 40</i>
VH 084P CNC 40	n° 4 mandrini a pinza min. 53,5 max. 137,5 completa di cono ISO 40	<i>4 spindles for spring collets min. 53,5 max. 137,5 with shank ISO 40</i>
VH 084/3P	n° 3 mandrini a pinza min. 53,5 max. 137,5	<i>3 spindles for spring collets min. 53,5 max. 137,5</i>
VH 102 LP	n° 2 mandrini a pinza min. 56 max. 148	<i>2 spindles for spring collets min. 56 max. 148</i>
VH 102 LD	n° 2 mandrini DIN 55058-12 min. 56 max. 148	<i>2 spindles DIN 55058-12 min. 56 max. 148</i>
VH 102 P CNC 40	n° 2 mandrini a pinza min. 28 max. 120 completa di cono ISO 40	<i>2 spindles for spring collets min. 28 max. 120 with shank ISO 40</i>
VH 102P R. 1-2	n° 2 mandrini a pinza min. 28 max. 120 rapporto 1-2	<i>2 spindles for spring collets min. 28 max. 120 ratio 1-2</i>
VH 102 PFM	n° 2 mandrini a pinza min. 28 max. 120 fora/maschia	<i>2 spindles for spring collets min. 28 max. 120 drilling and tapping</i>
VH 102-220 P	n° 2 mandrini a pinza min. 128 max. 220	<i>2 spindles for spring collets min. 128 max. 220</i>
VH 102-300 P	n° 2 mandrini a pinza min. 208 max. 300	<i>2 spindles for spring collets min. 208 max. 300</i>
VH 104D R.1-2	n° 4 mandrini a 90° DIN 55058-12 min. 60 max. 152 rapp. 1-2	<i>4 spindles at 90° DIN 55058-12 min. 60 max. 152 ratio 1-2</i>
VH 104P CNC50	n° 4 mandrini a 90° a pinza min. 60 max. 152 completa di cono ISO 50	<i>4 spindles at 90° for spring collets min. 60 max. 152 with shank ISO 50</i>
VH 132 LP	n° 2 mandrini a pinza min. 70 max. 186	<i>2 spindles for spring collets min. 70 max. 186</i>
VH 132 LD	n° 2 mandrini DIN 55058-16 min. 70 max. 186	<i>2 spindles DIN55058-16 min. 70 max. 186</i>
VH 132D CNC50	n° 2 mandrini DIN 55058-16 min. 35 max. 151 completa di cono ISO 50	<i>2 spindles DIN55058-16 min. 35 max. 151 with shank ISO 50</i>
VH 132P CNC50	n° 2 mandrini a pinza min. 35 max. 151 completa di cono ISO 50	<i>2 spindles for spring collets min. 35 max. 151 with shank ISO 50</i>
VH 132 W12	n° 2 mandrini foro cilindrico diam. 12 min. 35 max. 151	<i>2 spindles diam. 12 min. 35 max. 151</i>
VH 132-260 D	n° 2 mandrini DIN 55058-16 min. 144 max. 260	<i>2 spindles DIN 55058-16 min. 144 max. 260</i>
VH 134P CNC50	n° 4 mandrini a 90° a pinza, min. 75 max. 191 completa di cono ISO 50	<i>4 spindles at 90° for spring collets, min. 75 max. 191 with shank ISO 50</i>
VH 181 R 1-2	n° 1 mandrino diam. 16 min. 16,5 max. 82,5 rapp. 1-2	<i>1 spindle diam. 16, min. 16,5 max. 82,5 ratio 1-2</i>
VH 182 LP	n° 2 mandrini a pinza, min. 82 max. 214	<i>2 spindles for spring collets, min. 82 max. 214</i>
VH 182 LD	n° 2 mandrini DIN 55058-28 min. 82 max. 214	<i>2 spindles DIN 55058-28 min. 82 max. 214</i>
VH 182 W16	n° 2 mandrini foro cilindrico diam. 16 min. 41 max. 173	<i>2 spindles diam 16, min. 41 max. 173</i>
VH 182 P CNC 50	n° 2 mandrini a pinza, min. 41 max. 173 completa di cono ISO 50	<i>2 spindles for spring collets, min. 41 max. 173 with shank ISO 50</i>
VH 182 P R.1-2	n° 2 mandrini a pinza, min. 41 max. 173 173 rapp. 1-2	<i>2 spindles for spring collets, min. 41 max. 173 ratio 1-2</i>
VH 182D R. 1-2	n° 2 mandrini DIN 55058-28 min. 41 max. 173 rapp. 1-2	<i>2 spindles DIN 55058-28, min. 41 max. 173 ratio 1-2</i>
VH 183 L W16	n° 3 mandrini foro cilindrico diam. 16 min. 41+41 max. 107+107	<i>3 spindles diam.16 min. 41+41 max. 107+107</i>
VH 252 LD	n° 2 mandrini DIN 55058-36 min. 110 max. 294	<i>2 spindles DIN 55058-36, min. 110 max. 294</i>

Teste multiple ad assi variabili ◦ Variable axis heads

*galleria
fotografica*





Teste multiple ad assi variabili • Variable axis heads